

How to Crochet Sweaters:

5 FREE

Crochet Sweater Patterns

from
crochetme

crochetme
linking the crochet community

How to Crochet Sweaters: 5 FREE Crochet Sweater Patterns from *crochetme*



1 Singular Tee

Regina Rioux Gonzalez

2 Fuchsia & Blues Jacket

Pam Gillette

3 Mélange Turtleneck

Katie Himmelberg

4 Weekend Jacket

Annette Petavy

5 Wool Bam Boo Cardigan

Kristen TenDyke

How to Crochet Sweaters: 5 FREE Crochet Sweater Patterns

from 

YOU CAN NEVER HAVE TOO MANY SWEATERS! Cotton short-sleeved sweaters are perfect for summer or pair them with a long-sleeved shirt for spring and fall. Nothing is better than a warm, cozy cardigan on a chilly winter evening. And a beautiful sweater is a wonderful canvas on which to showcase the splendor of crochet, whether it's lace, Tunisian, or simple single crochet.

In this free eBook, we have collected a fun and unique selection of crocheted sweaters, cardigans, and pullovers just for you. Whether you are ready to begin your first sweater, start a cardigan as a gift, or looking for the perfect sweater to add to your collection, you will find something for everyone.

Created entirely with single crochet, the **Singular Tee** by Regina Rioux Gonzalez boasts flattering hourglass shaping and striking horizontal stripes. This crocheted sweater is simple enough to be your first sweater and a perfect year-round top.

The **Fuchsia and Blues Jacket** by Pam Gillette is a fabulous first sweater and a quick and satisfying project. This swing jacket is worked in a simple seed stitch that amplifies the texture of the bulky wool and cotton yarn. A striking single button fastens the neck of this A-line jacket.

Crochet and knit blend in the classic **Mélange Turtleneck** by Katie Himmelberg. The knitted bodice is elegantly tailored and crocheted shells create lacy long sleeves and collar. Both the bodice and lace are created with a soft baby alpaca yarn.

The **Weekend Jacket** by Annette Petavy marries a simple stitch pattern with broad horizontal stripes to create a cozy jacket, perfect for a relaxing weekend. This stylish cardigan has a classic collar, set-in sleeves, and simple waist shaping.

The **Wool Bam Boo Cardigan** by Kristen TenDyke is worked in Tunisian knit stitch, creating a warm and dense fabric. A delicate lace edging at the hem and cuffs adds a feminine touch to this warm cardigan.

So choose your favorite pattern and add another great sweater to your closet. I hope you enjoy the collection of free sweater patterns assembled in the *How to Crochet Sweaters: 5 Free Sweater Patterns from Crochet Me*.

Best wishes,

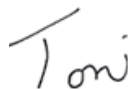

Toni
Editor, CrochetMe.com

P.S. Do you have friends who would like to crochet their first sweater and would appreciate free sweater patterns? Forward this link to them so they can download their own free copy of How to Crochet Sweaters: 5 Free Crochet Sweater Patterns from Crochet Me.

1	Singular Tee	Regina Rioux Gonzalez.....	PAGE 4
2	Fuchsia & Blues Jacket	Pam Gillette.....	PAGE 7
3	Mélange Turtleneck	Katie Himmelberg.....	PAGE 10
4	Weekend Jacket	Annette Petavy.....	PAGE 14
5	Wool Bam Boo Cardigan	Kristen TenDyke.....	PAGE 20
	Stitch Glossary		PAGE 25



HOW TO CROCHET SWEATERS:
5 FREE CROCHET SWEATER PATTERNS
FROM CROCHET ME

A Crochet Me eBook edited by
TONI REXROAT

EDITORIAL STAFF
EDITOR CROCHET ME Toni Rexroat

CREATIVE SERVICES
DESIGNER Charlene Tiedemann
PHOTOGRAPHY As noted
ILLUSTRATION Gayle Ford

Projects and information are for
inspiration and personal use only.

Singular Tee

design by Regina Rioux Gonzalez

Originally published in *Interweave Knitscene* Winter 2007/Spring 2008



Joe Hancock

ALLOVER SINGLE CROCHET is shaped for an hourglass fit in this springtime staple. The cap sleeves are more dynamic than dainty; the bold stripes more pirate than nautical! And, in a specially constructed cotton yarn, even single crochet has incredible drape and elasticity. Sized 32½"–46" bust.

SIZES 32½ (34, 36, 40, 44, 46)" bust

YARN Halcyon Casco Bay Sport (100% cotton ; 400 yd [365 m]/100 g):

- #107 tan (MC), 2 cones
- #133 brown (CC), 2 cones

GAUGE 18 sc and 24 rows = 4"

TOOLS

- Size F/5 (3.75 mm) crochet hook
- Yarn needle

See *glossary* for terms you don't know

STITCHES

Stripe Pattern: Alternate 6 rows MC, 6 rows CC. Do not fasten off color after first MC stripe. Join CC and carry MC along back of right side edge while CC is in use. Upon completion of CC stripe, drop color (do not fasten off) and beg working with MC while carrying strand of CC at back right side edge of stripe.

Body (make 2)

With MC, ch 79 (81, 85, 95, 105, 109). Work in stripe patt (see Stitches) as foll:

Row 1: (RS) Sc in 2nd ch from hook, sc in each ch to end, turn—78 (80, 84, 94, 104, 108) sc.

Rows 2–6: Ch 1, sc in each st to end.

Shape waist:

Row 7: (RS) Ch 1, sc2tog, sc in each st to last 2 sts, sc2tog, turn—2 sts dec'd.

Rows 8–12: Ch 1, sc in each st to end, turn.

Cont in stripe patt, rep Rows 7–12 only 4 (4, 3, 3, 3, 3) more times—68 (70, 76, 86, 96, 100) sts rem. Work even for 30 (30, 42, 42, 48, 48) rows—11 (11, 12, 12, 13, 13) stripes from beg. **Shape bust:**

Row 1: (RS) Ch 1, 2 sc in first st, sc in each st to last st, 2 sc in last st, turn—2 sts inc'd.

Rows 2–6: Ch 1, sc in each st to end, turn.

Rep Rows 1–6: one (two, one, one, one, one) more time(s)—72 (76, 80, 90, 100, 104) sts. Work 9 rows even, ending with a RS row. Fasten off and turn work.

Armholes: Maintain stripe patt and work as foll:

Row 1: (WS) Skip 2 (2, 2, 2, 4, 4) sts, join yarn to next st, sc in each st to last 2 (2, 2, 2, 4, 4) sts, fasten off, leaving rem sts unworked, turn—4 (4, 4, 4, 8, 8) sts dec'd; 68 (72, 76, 86, 92, 96) sts rem.

Row 2: (RS) Skip 2 (2, 2, 2, 3, 3) sts, join yarn in next st and sc in each st to last 2 (2, 2, 2, 3, 3) sts, turn, leaving rem sts unworked (do not fasten off)—4 (4, 4, 4, 6, 6) sts dec'd—64 (68, 72, 82, 86, 90) sts rem.

Row 3: Ch 1, sc2tog, sc in each st to last 2 sts, sc2tog, turn—2 sts dec'd.

Row 4: Ch 1, sc in each st to end, turn.

Rep Rows 3–4: only 3 (2, 2, 2, 2, 2) more times—56 (62, 66, 76, 80, 84) sts rem. Work 32 (34, 36, 38, 38, 38) rows even in patt—armholes should measure about 7½ (7½, 7½, 8, 8, 8)". Work 1 more row and place removable markers in 10 (11, 12, 15, 16, 17)th st from each edge. Fasten off.

Sleeve

With CC, ch 55 (55, 55, 65, 65, 65).

Row 1: (RS) Sc in 2nd ch from hook, sc in each of next 53 (53, 53, 63, 63, 63) chs, turn.

Pm in st 27 (27, 27, 32, 32, 32) of foundation ch.

Row 2: (WS) Ch 1, sc in each of next 32 (32, 32, 37, 37, 37) sts, turn.

Row 3: Ch 1, sc in each of next 10 sts, turn.

Row 4: Ch 1, sc in each of next 15 sts, turn.

Row 5: Ch 1, sc in each of next 20 sts, turn.

Row 6: Ch 1, sc in each of next 25 sts, turn.

Row 7: Ch 1, sc in each of next 30 sts, turn.

Row 8: Ch 1, sc in each of next 35 sts, turn.

Row 9: Ch 1, sc in each of next 40 sts, turn.

Row 10: Ch 1, sc in each of next 45 sts, turn.

Sizes 32½ (34)" only:

Row 11: (RS) Ch 1, [sc in each of next 8 sts, sc2tog] 5 times, turn.

Row 12: (WS) Ch 1, sc in each of next 40 sts, turn.

Row 13: Ch 1, sc in each of next 35 sts, turn.

Row 14: Ch 1, sc in each of next 30 sts, turn.

Row 15: Ch 1, sc in each of next 25 sts, turn.

Row 16: Ch 1, sc in each of next 20 sts, turn.

Row 17: Ch 1, sc in each of next 15 sts, turn.

Row 18: Ch 1, sc in each of next 10 sts, turn.

Row 19: Ch 1, sc in each of next 26 sts, turn.

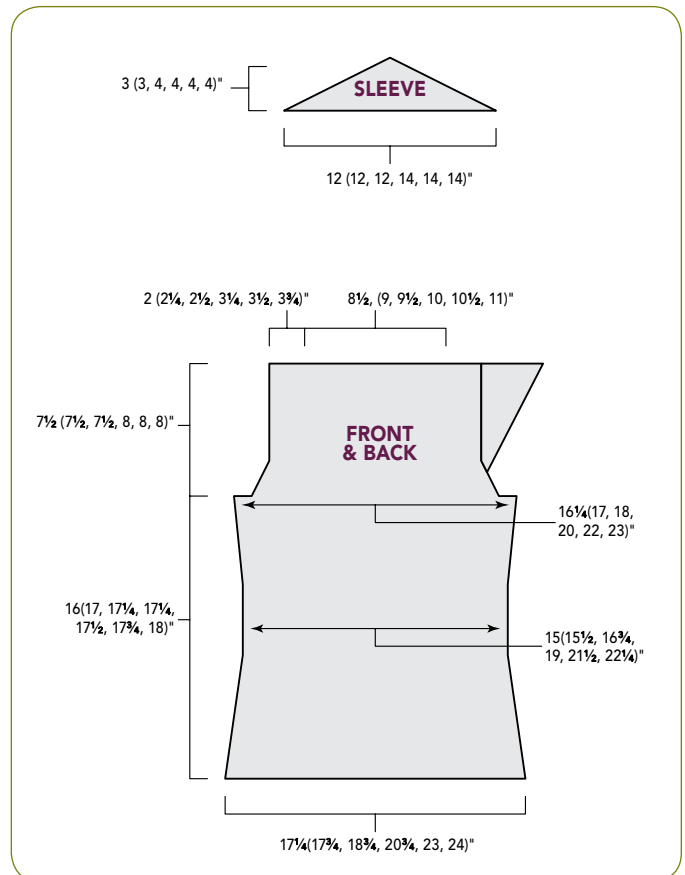

Row 20: Ch 1, [sc in each of next 7 sts, sc2tog] 5 times, sc in each of next 2 sts, fasten off.

Sizes 36 (40, 44, 46)" only:

Row 11: (RS) Ch 1, sc in each of next 50 sts, turn.

Row 12: (WS) Ch 1, sc in each of next 55 sts, turn.

Row 13: Ch 1, [sc in each of next 10 sts, sc2tog] 5 times, turn.

Row 14: Ch 1, sc in each of next 50 sts, turn.

Row 15: Ch 1, sc in each of next 45 sts, turn.

Row 16: Ch 1, sc in each of next 40 sts, turn.

Row 17: Ch 1, sc in each of next 35 sts, turn.

Row 18: Ch 1, sc in each of next 30 sts, turn.

Row 19: Ch 1, sc in each of next 25 sts, turn.

Row 20: Ch 1, sc in each of next 20 sts, turn.

Row 21: Ch 1, sc in each of next 15 sts, turn.

Row 22: Ch 1, sc in each of next 10 sts, turn.

Row 23: Ch 1, sc in each of next 31 sts, turn.

Row 24: Ch 1, [sc in each of next 9 sts, sc2tog] 5 times, sc in each of next 2 sts, fasten off.

Finishing

Pin body pieces tog with RS tog. Sew or sc side seams from the bottom edge to armholes matching stripes. Sew or sc shoulder seams from the outer edges to markers. Pin sleeve to armhole opening with RS tog so that middle of sleeve meets middle of shoulder. Pin sleeve down on each side of middle. Sew or sc sleeve to body. Rep for other sleeve. Sleeve edging: Join MC to underarm seam and sc around entire armhole opening, including sleeve edge. Sl st in beg sc to join. Fasten off. Rep for other sleeve. Weave in ends.

REGINA RIOUX GONZALEZ designs from her home in Los Angeles, California. Visit her at monstercrochet.blogspot.com.



Joe Hancock

Crochet stylish gifts for year-round giving!



Fuchsia & Blues Jacket

design by Pam Gillette

Originally published in *Interweave Crochet* Winter 2007



THIS SIMPLE A-LINE JACKET has a comfortable fit with a slight swing. The sleeves stop at the wrist to show off your favorite gloves or bracelet. Seed stitch adds texture, enhancing the inherent texture in the yarn. A large hook and bulky weight yarn makes this a quick and satisfying project.

FINISHED SIZE 32–34 (36–38, 40–42, 44–46, 48–50)" bust circumference. Jacket shown measures 36–38".

YARN Colinette Prism (70% wool, 30% cotton; 125 yd [114 m]/ 3 1/2 oz [100 g];): #048 Florentina, 7 (8, 9, 10, 11) skeins. Yarn distributed by Unique Colours.

HOOK SIZE K/10 1/2 (6.5 mm). Adjust hook size if necessary to obtain the correct gauge.

NOTIONS Yarn needle; 1 1/4" or 1 1/2" button.

GAUGE 10 sts and 11 rows = 4" in seed st patt.

SKILL LEVEL Easy.

NOTES The back, 2 front pieces, and sleeves are worked separately then sewn together. Tch does not count as st throughout patt.

Kathryn Martin



Kathryn Martin

Rows 6–9: Work seed st patt (see Stitch Guide) across, turn.

Row 10: Rep Row 5—49 (51, 55, 59, 63) sts.

Rows 11–14: Work seed st patt across, turn.

Row 15: Rep Row 5—47 (49, 53, 57, 61) sts.

Rows 16–19: Work seed st patt across, turn.

Row 20: Rep Row 5—45 (47, 51, 55, 59) sts.

Rows 21–24: Work seed st patt across, turn.

Row 25: Rep Row 5—43 (45, 49, 53, 57) sts.

Rows 26–29: Work seed st patt across, turn.

Row 30: Rep Row 5—41 (43, 47, 51, 55) sts.

Rows 31–34: Work seed st patt across, turn.

Row 35: Rep Row 5—39 (41, 45, 49, 53) sts.

Row 36: Work seed st patt across, turn.

STITCH GUIDE

Seed Stitch (over a multiple of 2 sts + 1)

Row 1: Ch 1, sc in next st, *hdc in next sc, sc in next hdc; rep from * across, turn.

Row 2: Ch 2, hdc in next st, *sc in next hdc, hdc in next sc; rep from * across, turn.

Rep Rows 1–2 for seed st patt.

Back

Ch 55 (57, 61, 65, 69).

Row 1: Hdc in 3rd ch from hook, *sc in next ch, hdc in next ch; rep from * across, turn—53 (55, 59, 63, 67) sts.

Row 2: Ch 1, sc in first hdc, *hdc in next sc, sc in next hdc; rep from * across, turn.

Row 3: Ch 2, hdc in first sc, *sc in next hdc, hdc in next sc; rep from * across, turn.

Row 4: Rep Row 2.

Row 5 (dec row): Ch 2, sc2tog (see Glossary) in first 2 sts, work seed st patt to last 2 sts, sc2tog over rem 2 sts—51 (53, 57, 61, 65) sts.

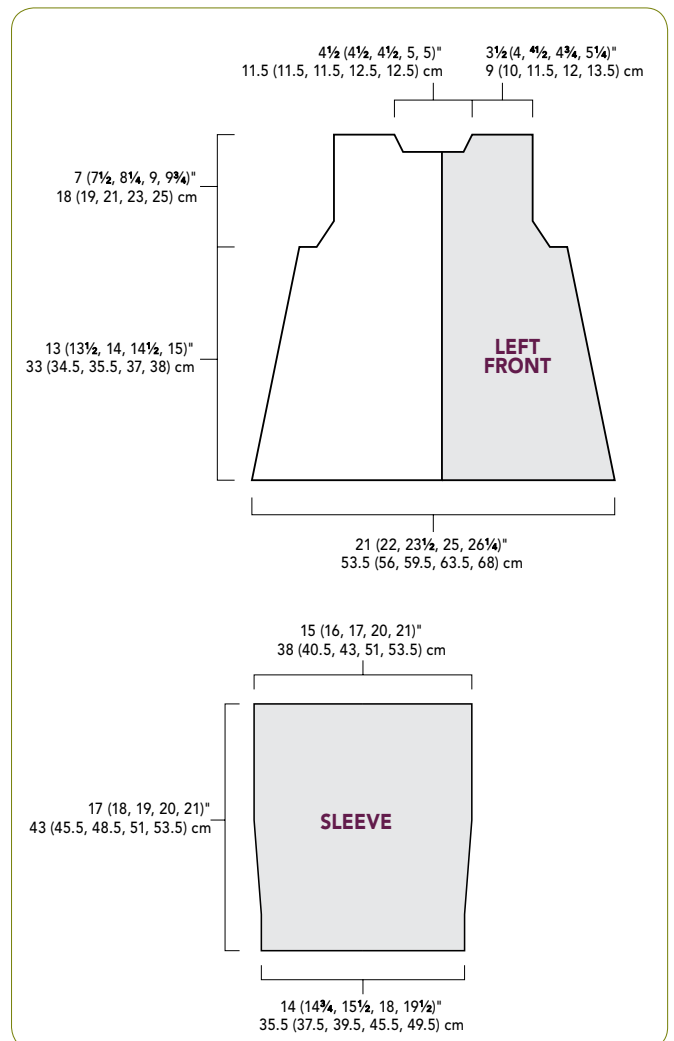

Sizes 36–38 (40–42, 44–46, 48–50)" only: Cont to work even in seed st patt until piece measures 13½(14, 14½, 15)" from beg. **All sizes: Shape armholes:**

Row 1: Sl st in first 5 (5, 6, 6, 7) sts, work seed st patt to last 5 (5, 6, 6, 7) sts, leave rem sts unworked, turn—29 (31, 33, 37, 39) sts.

Rows 2–16 (18, 20, 22, 24): Work seed st patt across, turn. **Shape neck:**

Row 1: Work seed st patt over next 9 (10, 11, 12, 13) sts for first shoulder, leave rem sts unworked, turn.

Rows 2–3: Work even in patt on 9 (10, 11, 12, 13) sts. Fasten off.

Return to last full row worked, sk center 11 (11, 11, 13, 13) neck sts, join yarn with sl st in next st, work seed st patt to end for second shoulder, turn.

Rows 2–3: Work even in patt on 9 (10, 11, 12, 13) sts. Fasten off.



Kathryn Martin

Front (make 2)

Ch 27 (29, 31, 33, 37).

Row 1: Hdc in 3rd ch from hook, *sc in next ch, hdc in next ch; rep from * across, turn—25 (27, 29, 31, 35) sts.

Rows 2–4: Work seed st patt across, turn.

Row 5 (dec row): Ch 2, sc2tog over first 2 sts, work seed st patt to end, turn—24 (26, 28, 30, 34) sts.

Rep Rows 2–5 six times. Cont even in patt until piece measures 13 (13½, 14, 14½, 15)" from beg. **Shape armhole:**

Row 1: Sl st in first 5 (5, 6, 6, 7) sts, work seed st patt to end, turn—13 (15, 16, 18, 21) sts.

Rows 2–16 (18, 20, 22, 24): Work seed st patt to end, turn.

Shape neck

Row 1: Work seed st patt for 9 (10, 11, 12, 13) sts, leave rem sts unworked, turn.

Rows 2–3: Ch 2, work seed st patt on 9 (10, 11, 12, 13) sts. Fasten off.

Sleeves

Ch 37 (39, 41, 47, 51).

Row 1: Hdc in 3rd ch from hook, *sc in next ch, hdc in next ch; rep from * across, turn—35 (37, 39, 45, 49) sts.

Rows 2–9: Work seed st patt across, turn.

Row 10 (inc row): Ch 2, (hdc, sc) in first st, cont in est seed st patt to last st, (sc, hdc) in last st—37 (39, 41, 47, 51) sts.

Rep Rows 2–10 zero (one, one, one, one) more time—37 (41, 43, 49, 53) sts. Work even in est patt until sleeve measures 17 (18, 19, 20, 21)" from beg. Fasten off.

Finishing

Buttonband: On right front, with RS facing, join yarn with sl st at lower right corner, ch 1, sc evenly in row ends until 3 rows from neck edge, ch 5 for buttonhole, sk 3 rows, sc in top st, ch 1, turn, sc back down right front working 5 sc in ch-5 sp, sl st in beg ch-1. Fasten off. Rep sc edging on left-front panel omitting ch-5 buttonhole. Block all pieces to measurements according to schematic. With yarn, yarn needle, and RS facing, sew fronts to back at shoulder seams. Set in sleeves and sew in place. Sew side and sleeve seams. Weave in all loose ends. **Edging:** Working from left to right, join yarn with sl st and work 1 row rev sc (see Glossary), evenly on all edges, working 2 sts in each corner. Sew button on left front opposite buttonhole.

PAM GILLETTE was born and raised in Minnesota, where a sweater is required eight months of the year. She thinks about crochet 24–7 and works at making her blog funky, cool, new, and knotty at www.knottygeneration.com.

Mélange Turtleneck

design by Katie Himmelberg

Originally published in *Interweave Crochet* Winter 2007



Kathryn Martin

BABY ALPACA YARN LENDS ITS COMFORTINGLY SOFT HALO to this knit and crocheted sweater. Tailored for a full-fashioned fit, you can wear it on its own or layered over a long-sleeve top for added warmth from the lace sleeves.

FINISHED SIZE 34 (38, 42, 46, 50)" bust circumference. Garment shown measures 34". Fit is snug; allow 0–2" of negative ease.

YARN Blue Sky Alpacas Mélange (100% baby alpaca; 110 yd [100 m]/1¾ oz [50 g]); #807 Dijon (A), 6 (7, 8, 10, 11) skeins and #802 pesto (B), 5 (7, 7, 8, 9) skeins.

HOOK SIZE G/7 (4 mm). Adjust hook size if necessary to obtain the correct gauge.

NEEDLES Sizes 2 (2.75 mm) and 3 (3.25 mm): 22" circular (cir). Adjust needle size if necessary to obtain the correct gauge.

NOTIONS Stitch markers (m); yarn needle; waste yarn.

Gauge 24 sts and 32 mds = 4" in St st in the rnd on larger needle. One perky sh patt rep = 2"; 4 rows = 1½".

SKILL LEVEL Intermediate.

Stitch Guide

Perky shells (perky sh; a multiple of 10 sts + 2)

Row 1: (RS) Sc in 2nd ch from hook, sc in next ch, ch 3, sk next 2 ch, dc in next ch, ch 1, sk next ch, dc in next ch, ch 3, *sk next 2 ch, sc in next ch, ch 1, sk next ch, sc in next ch, ch 3, sk next 2 ch, dc in next ch, ch 1, sk next ch, dc in next ch, ch 3; rep from * to last 4 ch, sk next 2 ch, sc in rem 2 ch, turn.

Row 2: (WS) Ch 3 (counts as first dc here and throughout), dc in next sc, ch 3, sk next ch-3 sp, sc in next ch-1 sp, ch 3, *sk next ch-3 sp, dc in next ch-1 sp, [ch 1, dc in same sp] twice, ch 3, sk next ch-3 sp, sc in next ch-1 sp, ch 3; rep from * to last ch-3 sp, sk last ch-3 sp, dc in rem 2 sc, turn.

Row 3: Ch 3, dc in next dc, ch 3, sc in next ch-3 sp, ch 1, sc in next ch-3 sp, ch 3, *dc in next ch-1 sp, ch 1, dc in next ch-1 sp, ch 3, sc in next ch-3 sp, ch 1, sc in next ch-3 sp, ch 3; rep from * to last 2 dc, dc in rem 2 dc, turn.

Row 4: Ch 1, sc in first 2 dc, ch 3, sk next ch-3 sp, dc in next ch-1 sp, [ch 1, dc in same sp] twice, ch 3, *sk next ch-3 sp, sc in next ch-1 sp, ch 3, sk next ch-3 sp, dc in next ch-1 sp, [ch 1, dc in same sp] twice, ch 3; rep from * to last ch-3 sp, sk last ch-3 sp, sc in rem 2 dc, turn.

Row 5: Ch 1, sc in first 2 sc, ch 3, sk next ch-3 sp, dc in next ch-1 sp, ch 1, dc in next ch-1 sp, ch 3, *sc in next ch-3 sp, ch 1, sc in next ch-3 sp, ch 3, dc in next ch-1 sp, ch 1, dc in next ch-1 sp, ch 3; rep from * to last ch-3 sp, sk last ch-3 sp, sc in rem 2 sc, turn.

Rep Rows 2–5 for patt.

Body

With A and smaller cir needle, CO 202 (225, 246, 273, 297) sts. Place marker (pm) to indicate beg of rnd and join, being careful not to twist sts. Work in St st (knit every rnd) for 10 rnds. Purl 1 rnd. Switch to larger cir needle and knit 10 rnds. Join CO edge to working rnd to form hem by working every other stitch through both ends as foll: **Next rnd:** fold up hem along purl line with WS tog so the CO edge lies parallel to needles. *K1, k2tog (insert left-hand needle in 1 st from CO edge, work as k2tog

with live stitch on needle); rep from * around. Cont in St st until piece measures 3 (3, 3½, 4, 5)" from hem fold line, ending with a WS row. **Shape Waist:** K27 (29, 32, 34, 38), ssk (see Glossary), pm, k50 (56, 62, 70, 74), pm, k2tog, k27 (29, 32, 34, 38), pm for side seam, k27 (29, 32, 34, 38), ssk, pm, k36 (45, 51, 59, 63), pm, k2tog, k27 (29, 32, 34, 38)—198 (221, 245, 269, 293) sts. *Work 2 rnds even. **Dec rnd:** Knit to 2 sts before first m, ssk, sl m, knit to next m, sl m, k2tog, knit to next m, slip m (side seam m), knit to 2 sts before next m, ssk, sl m, knit to next m, sl m, k2tog, knit to end of rnd. Rep from * 7 more times (9 dec rnds worked)—166 (189, 213, 237, 261) sts rem. Work even in St st until piece measures 7½ (7½, 8, 8½, 9½)" from hem fold line. ***Inc rnd:** Knit to m, M1 (see Glossary), sl m, knit to next m, sl m, M1, knit to next m, sl m (side seam m), knit to next m, M1, sl m, knit to next m, sl m, M1, knit to end of rnd. Work 2 rnds even. Rep from * 8 more times (9 inc rnds worked)—202 (225, 249, 273, 297) sts. Removing all m except beg-of-rnd m and side-seam m, work even until piece measures 14 (14, 14½, 15, 16)" from hem fold line.

Front

Shape armholes: BO 5 (5, 6, 7, 8) sts at beg of next rnd, knit to side-seam m, place rem 94 (107, 119, 131, 143) sts on holder for back. Begin working back and forth in rows as foll: **Next row:** (WS) BO 5 (5, 6, 7, 8) sts, purl to end of row. Dec 1 st each end of every other row 4 (5, 6, 7, 8) times, then every 4 rows 3 (3, 4, 5, 6) times as foll: (RS) K1, ssk, knit to last 3 sts, k2tog, k1—84 (92, 98, 104, 110) sts rem. Work even in St st until armholes measure 6 (6½, 7, 7½, 8)" ending with a WS row. **Shape neck:** (RS) K33 (35, 37, 39, 41), attach new ball of yarn and BO center 18 (22, 24, 26, 28) sts, knit to end—33 (35, 37, 39, 41) sts rem each side. Working both sides separately at the same time, work one WS row even, then BO 2 sts at each neck edge 4 (5, 5, 5, 5) times. Dec 1 st at each neck edge every row 4 (4, 6, 8, 7) times, and at the same time, when armholes measure 7½ (8, 8½, 9, 9½)" and ending WS row begin shoulder shaping. **Shape shoulders:** (RS) BO 4 (4, 4, 4, 5) sts at beg of next 2 rows, BO 5 sts at beg of next 2 rows, BO 5 (5, 5, 5, 7) sts at beg of next 2 rows, BO 7 sts at beg of next 2 rows.

Back

Place held sts on larger cir needle—94 (107, 119, 131, 143) sts. **Shape armholes:** (RS) BO 5 (5, 6, 7, 8) sts at beg of next 2 rows. Dec 1 st each end every other row 4 (5, 6, 7, 8) times, then every 4 rows 3 (3, 4, 5, 6) times as foll: (RS) K1, ssk, knit to last 3 sts, k2tog, k1—70 (81, 87, 93, 99) sts rem. Work even in St st until armholes measure 7½ (8, 8½, 9, 9½)", ending with a WS row. **Shape shoulders and neck:** Mark center 28 (39, 45, 51, 51) sts. (RS) BO 4 (4, 4, 4, 5) sts at beg of next 2 rows, ending with a WS row. **Next row:** (RS) BO 5 sts, work to marked sts, join new ball of yarn and BO 28 (39, 45, 51, 51) sts, work to end. BO 5 sts at beg of next row, BO 5 (5, 5, 5, 7) sts at beg of next 2 rows, BO 7 sts at beg of next 2 rows.

Sleeves

Note: Sleeve is worked from the top down. Sleeve cap is inc'd to underarm, sleeve is worked even to cuff, then cuff is shaped.

With B, ch 32 (42, 42, 52, 52). Work in perky sh patt (see Stitch Guide) for 3 rows. **Shape cap:**

Row 4: Ch 3, sc in 2nd and 3rd ch from hook, sc in first 2 dc, ch 3, sk next ch-3 sp, dc in next ch-1 sp, [ch 1, dc in same sp] twice, ch 3, *sk next ch-3 sp, sc in next ch-1 sp, ch 3, sk next ch-3 sp, dc in next ch-1 sp, [ch 1, dc in same sp] twice, ch 3; rep from * to last ch-3 sp, sk last ch-3 sp, sc in rem 2 dc, turn.

Row 5: Ch 3, sc in 2nd and 3rd ch from hook, sc in first 2 sc, ch 3, sk next ch-3 sp, dc in next ch-1 sp, ch 1, dc in next ch-1 sp, ch 3, *sc in next ch-3 sp, ch 1, sc in next ch-3 sp, ch 3, dc in next ch-1 sp, ch 1, dc in next ch-1 sp, ch 3; rep from * to last ch-3 sp, sk last ch-3 sp, sc in rem 4 sc, turn.

Row 6: Ch 3, dc in next 3 sc, ch 3, sk next ch-3 sp, sc in next ch-1 sp, ch 3, *sk next ch-3 sp, dc in next ch-1 sp, [ch 1, dc in same sp] twice, ch 3, sk next ch-3 sp, sc in next ch-1 sp, ch 3; rep from * to last ch-3 sp, sk last ch-3, dc in last 4 sc, turn.

Row 7: Ch 3, dc in next 3 dc, ch 3, sc in next ch-3 sp, ch 1, sc in next ch-3 sp, ch 3, *dc in next ch-1 sp, ch 1, dc in next ch-1 sp, ch 3, sc in next ch-3 sp, ch 1, sc in next ch-3 sp, ch 3; rep from * to last 4 dc, dc in rem 4 dc, turn.

Row 8: Ch 3, sc in 2nd and 3rd ch from hook, sc in next 4 dc, ch 3, sk next ch-3 sp, dc in next ch-1 sp, [ch 1, dc in same sp] twice, ch 3, *sk next ch-3 sp, sc in next ch-1 sp, ch 3, sk next ch-3 sp, dc in next ch-1 sp, [ch 1, dc in



Kathryn Martin

same sp] twice, ch 3; rep from * to last ch-3 sp, sk last ch-3 sp, sc in rem 4 dc, turn.

Row 9: Ch 3, sc in 2nd and 3rd ch from hook, sc in next 4 sc, ch 3, sk next ch-3 sp, dc in next ch-1 sp, ch 1, dc in next ch-1 sp, ch 3, *sc in next ch-3 sp, ch 1, sc in next ch-3 sp, ch 3, dc in next ch-1 sp, ch 1, dc in next ch-1 sp, ch 3; rep from * to last ch-3 sp, sk last ch-3 sp, sc in rem 6 sc, turn (1 full rep inc'd; half on each side).

Row 10: Ch 5, sk next 2 sc, dc in next sc, [ch 1, dc in same sc] twice, ch 3, sk next ch-3 sp, sc in next ch-1 sp, ch 3, *sk next ch-3 sp, dc in next ch-1 sp, [ch 1, dc in same sp] twice, ch 3, sk next ch-3 sp, sc in next ch-1 sp, ch 3; rep from * to last ch-3 sp, sk last ch-3 sp, sk next 2 sc, dc in next sc, [ch 1, dc in same sc] twice, ch 3, dc in rem sc, turn.

Row 11: Ch 6, dc in next ch-1 sp, ch 1, dc in next ch-1 sp, ch 3, *sc in next ch-3 sp, ch 1, sc in next ch-3 sp, ch 3, dc in next ch-1 sp, ch 1, dc in next ch-1 sp, ch 3; rep from * to last dc, dc in rem dc, turn.

Row 12: Ch 3, sc in 2nd and 3rd ch from hook, sc in next dc, ch 3, sc in next ch-1 sp, ch 3, dc in next ch-1 sp,

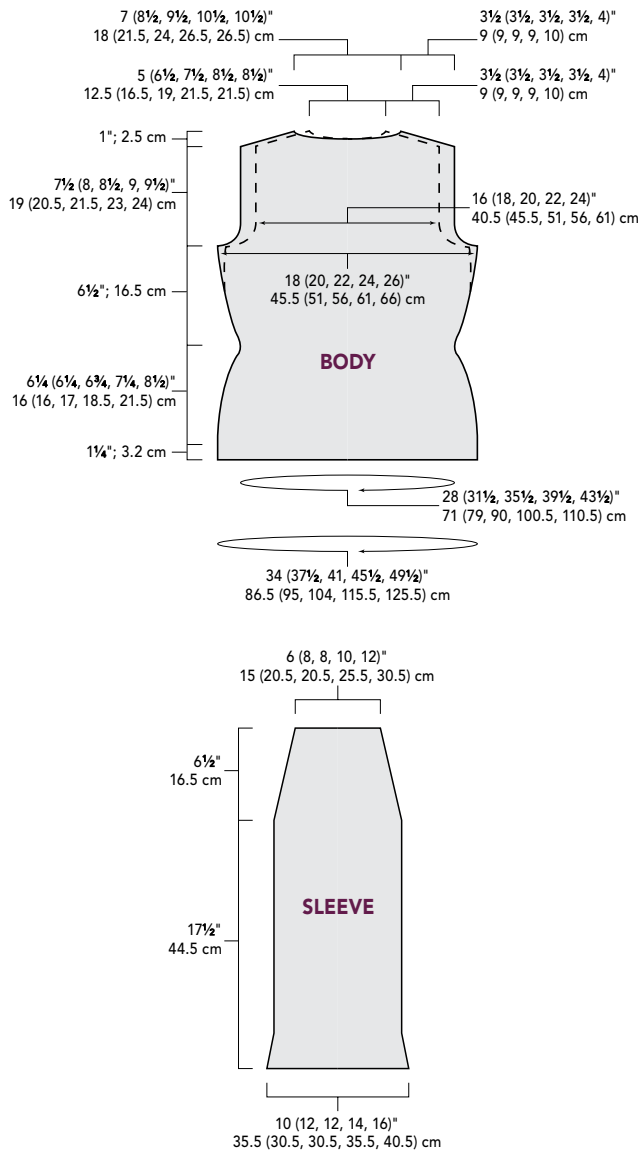

[ch 1, dc in same sp] twice, ch 3, *sk next ch-3 sp, sc in next ch-1 sp, ch 3, sk next ch-3 sp, dc in next ch-1 sp, [ch 1, dc in same sp] twice, ch 3; rep from * to last dc, sc in last dc, turn.

Row 13: Ch 3, sc in 2nd and 3rd ch from hook, ch 3, sc in next ch-3 sp, ch 1, sc in next ch-3 sp, ch 3, *dc in next ch-1 sp, ch 1, dc in next ch-1 sp, ch 3, sc in next ch-3 sp, ch 1, sc in next ch-3 sp, ch 3; rep from * to last 3 sc, sc in rem 3 sc, turn.

Row 14: Ch 3, dc in next 2 dc, ch 3, sk next ch-3 sp, dc in next ch-1 sp, [ch 1, dc in same sp] twice, ch 3, sk next ch-3 sp, *sc in next ch-1 sp, ch 3, sk next ch-3 sp, dc in next ch-1 sp, [ch 1, dc in same sp] twice, ch 3, sk next

ch-3 sp; rep from * to last 3 sc, dc in rem 3 sc, turn.

Row 15: Ch 3, dc in next 2 dc, ch 3, sk next ch-3 sp, dc in next ch-1 sp, ch 1, dc in next ch-1 sp, ch 3, *sc in next ch-3 sp, ch 1, sc in next ch-3 sp, ch 3, dc in ch-1 sp, ch 1, dc in next ch-1 sp, ch 3; rep from * to last ch-3 sp, sk last ch-3 sp, dc in rem 3 dc, turn.

Row 16: Ch 3, sc in 2nd and 3rd ch from hook, sc in next 3 dc, ch 3, sk next ch-3 sp, sc in next ch-1 sp, ch 3, sk next ch-3 sp, *dc in next ch-1 sp, [ch 1, dc in same sp] twice, ch 3, sk next ch-3 sp, sc in next ch-1 sp, ch 3, sk next ch-3 sp; rep from * to last 3 dc, sc in rem 3 dc, turn.

Row 17: Ch 3, sc in 2nd and 3rd ch from hook, sc in next 3 sc, ch 3, sc in next ch-3 sp, ch 1, sc in next ch-3 sp, ch 3, *dc in next ch-1 sp, ch 1, dc in next ch-1 sp, ch 3, sc in next ch-3 sp, ch 1, sc in next ch-3 sp, ch 3; rep from * to last 5 sc, sc in rem 5 sc, turn.

Row 18: Ch 3, dc in first sc, ch 3, sk next 2 sc, sc in next sc, ch 3, sk next ch-3 sp, dc in next ch-1 sp, [ch 1, dc in same sp] twice, ch 3, sk next ch-3 sp, *sc in next ch-1 sp, ch 3, sk next ch-3 sp, dc in next ch-1 sp, [ch 1, dc in same sp] twice, ch 3, sk next ch-3 sp; rep from * to last 5 sc, sk next sc, sc in next sc, ch 3, 2 dc in rem sc, turn (2 full reps inc'd; 1 on each side).

Cont in perky sh patt, starting with Rows 3–5, then working Rows 2–5 eleven more times. *Note:* To adjust length of sleeve, add or remove a rep of Rows 2–5 here; each rep adds about 1½".

Shape cuff: Cont in perky sh patt, working all "ch-3" as "ch-4" except for tch. Work Rows 2–5 once, then work Rows 2–4 once more.

Finishing

With yarn threaded on yarn needle, sew shoulder seams. **Collar:** With WS facing, B, and beg at front left side of neck, sc 85 (95, 105, 115, 125) evenly around neck opening, then ch 7–92 (102, 112, 122, 132) sts. Work Rows 1–5 of perky sh patt once, then work Rows 2–5 three more times. Fasten off. Wet-block pieces to measurements, pinning out lace on sleeves and collar. With yarn threaded on yarn needle, sew sleeve seams. Sew in sleeves. Sew ch-7 of right side of collar overlapping the left side of collar. With B, sew buttons to collar, using holes created by patt as buttonholes.

KATIE HIMMELBERG appreciates the strengths of crochet and knitting and enjoys projects that celebrate both. She mixes knit and crochet from her home in Loveland, Colorado.

Weekend Jacket

design by Annette Petavy

Originally published in
Interweave Crochet Spring 2007



Kathryn Martin

RELAX THIS WEEKEND with an easy stitch pattern and a wonderfully cozy yarn—but do it in style, with waist shaping and set-in sleeves. Color-blocking adds visual interest and variety to the simple stitch pattern.

FINISHED SIZE 37½ (39¾, 41¾, 44¼, 46)" bust circumference, zipped. Jacket shown measures 37½".

YARN RY Classic Cashcotton DK (35% cotton, 25% polyamide, 18% angora, 13% viscose, 9% cashmere; 142 yd [130 m]/1¼ oz [50 g]): #606 quartz (MC), 8 (9, 9, 10, 10) balls; #603 apple (CC1) and #615 wheat (CC2), 2 (2, 3, 3, 3) balls each. Yarn distributed by Westminster Fibers.

HOOK SIZE G/7 (4.5 mm). Adjust hook size if necessary to obtain the correct gauge.

NOTIONS Removable markers (m); yarn needle; 20 (22, 22, 22, 22)" zipper to match MC.

GAUGE 16 sts and 11½ rows = 4" in hdc-flo.

SKILL LEVEL Easy.

Stitch Guide

Hdc flo: Hdc through front loop only.

Sc flo: Sc through front loop only.

Hdc2tog flo: Yo, insert hook in flo of next st, yo, draw up a lp (3 lps on hook), yo, insert hook in flo of next st, yo, draw up a lp (5 lps on hook), yo, draw through all 5 lps on hook.

Front Color Blocks: 12 rows MC, 12 rows CC1, 12 rows CC2, 12 rows MC, 12 rows CC1. Work with CC2 for remainder of piece.

Notes

The entire garment is worked with stitches made through the front loop only (flo).

Turning chain does not count as a stitch throughout pattern.

When shaping the armholes, sleeve caps, and neck, the stitches worked as slip stitches at the beginning of row or skipped at the end of row are counted as decreases and are not included in the stitch count at the end of the row.

Back

With MC, ch 78 (82, 86, 92, 96).

Row 1: (RS) Hdc in 3rd ch from hook and in each ch across, turn—76 (80, 84, 90, 94) hdc.

Row 2: Ch 2, working through the flo here and throughout (see Stitch Guide and Notes), hdc in each st across, turn.

Rep Row 2. Work a total of 4 rows in MC, 2 rows in CC1, 2 rows in CC2, and then cont in MC only. At the same time, **shape waist as foll:** When piece measures 43/4 (6, 6, 6, 6)" from beg, ending with a WS row, *work 24 (24, 26, 28, 30) sts in patt, hdc2tog 2 times (see Stitch Guide), work in patt to last 28 (28, 30, 32, 34) sts, hdc2tog 2 times, work in patt to end—4 sts dec'd. Work 1 row even in patt. Rep from * 2 more times—64 (68, 72, 78, 82) sts rem. Work even in patt until piece measures 9½ (11½, 11½, 11½, 11½)" from beg, ending with a WS row. **Shape bust:** **Work 24 (24, 26, 28, 30) sts in patt, [2 hdc in next st] 2 times, work in patt to last 26 (26, 28, 30, 32) sts, [2 hdc in next st] 2 times, work in patt to end—4 sts inc'd. Work 1 row even. Rep from ** 2 more times—76 (80, 84, 90, 94) sts. Work even in patt until piece measures 15¾ (17¼, 17, 17, 17)" from beg, ending with a WS row. **Shape armholes:**

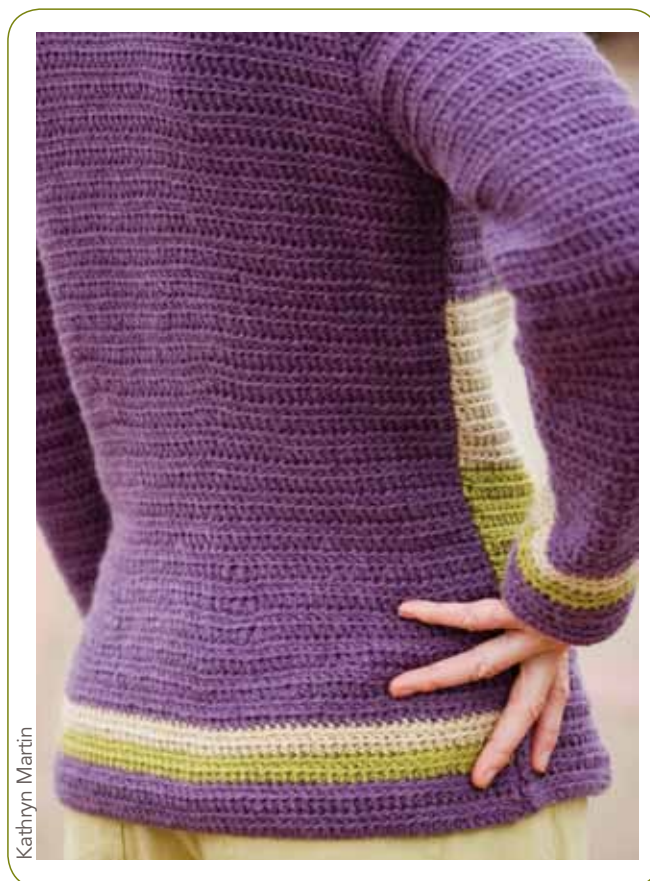

Kathryn Martin

Row 1: Sl st in each of first 2 (5, 5, 5, 8) sts, sc in next st, hdc in each st to last 3 (6, 6, 6, 9) sts, sc in next st, turn—72 (70, 74, 80, 78) sts rem.

Row 2: Sl st in each of first 2 (1, 1, 2, 2) st(s), sc in next st, hdc in each st to last 3 (2, 2, 3, 3) sts, sc in next st, turn, leaving rem sts unworked—68 (68, 72, 76, 74) sts rem.

Row 3: Sl st in each of first 1 (1, 2, 1, 1) st(s), ch 0 (0, 1, 0, 0), sc in next 1 (1, 0, 1, 1) st, hdc in each st to last 2 sts, sc in next 1 (1, 0, 1, 1) st, turn—66 (66, 68, 74, 72) sts rem.

Row 4: Sl st in each of first 1 (1, 1, 2, 1) st(s), ch 1 (1, 1, 1, 0), sc in next 0 (0, 0, 0, 1) st, hdc in each st to last 1 (1, 1, 2, 2) st(s), sc in next 0 (0, 0, 0, 1) st, turn—64 (64, 66, 70, 70) sts rem.

Row 5: Sl st in first 1 (0, 0, 0, 1) st, ch 1 (2, 1, 1, 1), sc in next 0 (0, 1, 1, 0) st, hdc in each st to last 1 (0, 1, 1, 1) st, sc in next 0 (0, 1, 1, 0) st, turn—62 (64, 66, 70, 68) sts rem.

Row 6: Sl st in first 0 (1, 1, 1, 0) st, ch 2 (1, 1, 0, 1), sc in next 0 (0, 0, 1, 1) st, hdc in each st to last 0 (1, 1, 2, 1) st(s), sc in next 0 (0, 0, 1, 1) st, turn—62 (62, 64, 68, 68) sts rem.

Row 7: Sl st in first 0 (0, 0, 1, 1) st, ch 2 (2, 2, 1, 1), hdc in each st across to last 0 (0, 0, 1, 1) st, turn—62 (62, 64, 66, 66) sts rem.

Row 8: Sl st in first 1 (0, 1, 0, 0) st, ch 1 (2, 1, 2, 1), sc in next 0 (0, 0, 0, 1) st, hdc in each st to last 1 (0, 1, 0, 1) st, sc in next 0 (0, 0, 0, 1) st, turn—60 (62, 62, 66, 66) sts rem.

Row 9: Sl st in first 0 (0, 0, 0, 1) st, ch 2 (2, 2, 1, 1), sc in next 0 (0, 0, 1, 0) st, hdc in each st to last 0 (0, 0, 1, 1) st, sc in next 0 (0, 0, 1, 0) st, turn—60 (62, 62, 66, 64) sts rem.

Size 44¼" only:

Row 10: Sl st in first st, ch 1, hdc in each st to last st, turn, leaving rem st unworked—64 sts.

All sizes:

Work even in patt until armholes measure 7 (7½, 7¾, 7¾, 7¾)". **Shape shoulder and neck:**

Row 1: Sl st in each of first 2 (2, 2, 3, 3) sts, sc in each of next 1 (2, 2, 2, 2) st(s), hdc in each st to last 3 (4, 4, 5, 5) sts, sc in each of next 1 (2, 2, 2, 2) st(s), turn—56 (58, 58, 58) sts rem.

Row 2: Sl st in each of first 4 (5, 5, 5, 5) sts, sc in each of next 2 sts, hdc in each st to last 6 (7, 7, 7, 7) sts, sc in each of next 2 sts, turn—48 (48, 48, 48) sts rem.

Row 3: Sl st in each of first 5 (5, 5, 4, 4) sts, sc in each of next 2 sts, hdc in each of next 7 sts, sc in each of next 2 sts, sl st in each of next 16 (16, 16, 18, 18) sts, sc in each of next 2 sts, hdc in each of next 7 sts, sc in each of next 2 sts—38 (38, 38, 40, 40) sts rem. Fasten off.

Left Front

Work left front in color blocks (see Stitch Guide). With MC, ch 40 (42, 44, 47, 49).

Row 1: Hdc in 3rd ch from hook and in each ch across, turn—38 (40, 42, 45, 47) hdc.

Row 2: Ch 2, working through the flo here and throughout, hdc in each st across, turn.

Rep Row 2 for patt. Cont in patt until piece measures 4¾ (6, 6, 6, 6)" from beg, ending with a WS row. **Shape waist:** *Work 20 (20, 22, 24, 26) sts in patt, hdc2tog 2 times, work in patt to end—2 sts dec'd. Work 1 row

even in patt. Rep from * 2 more times—32 (34, 36, 39, 41) sts rem. Work even in patt until piece measures 9½ (11½, 11½, 11½, 11½)" from beg, ending with a WS row. **Shape bust:** **Work 20 (20, 22, 24, 26) sts in patt, [2 hdc in next st] 2 times, work in patt to end—2 sts inc'd. Work 1 row even. Rep from ** 2 more times—38 (40, 42, 45, 47) sts. Work even in patt until piece measures 15¾ (17¼, 17, 17, 17)" from beg, ending with a WS row. **Shape armhole:**

Row 1: Sl st in each of first 2 (5, 5, 5, 8) sts, sc in next st, hdc in each st across, turn—36 (35, 37, 40, 39) sts rem.

Row 2: Ch 2, hdc in each st to last 3 (2, 2, 3, 3) sts, sc in next st, turn—34 (34, 36, 38, 37) sts rem.

Row 3: Sl st in each of first 1 (1, 2, 1, 1) st(s), ch 0 (0, 1, 0, 0), sc in next 1 (1, 0, 1, 1) st, hdc in each st across, turn—33 (33, 34, 37, 36) sts rem.

Row 4: Ch 2, hdc in each st to last 1 (1, 1, 2, 2) st(s), sc in next 0 (0, 0, 0, 1) st, turn—32 (32, 33, 35, 35) sts rem.

Row 5: Sl st in first 1 (0, 0, 0, 1) st, ch 1 (2, 1, 1, 1), sc in next 0 (0, 1, 1, 0) st, hdc in each st across, turn—31 (32, 33, 35, 34) sts rem.

Row 6: Ch 2, hdc in each st to last 0 (1, 1, 2, 1) st(s), sc in next 0 (0, 0, 1, 1) st, turn—31 (31, 32, 34, 34) sts rem.

Row 7: Sl st in first 0 (0, 0, 1, 1) st, ch 2 (2, 2, 1, 1), hdc in each st across, turn—31 (31, 32, 33, 33) sts rem.

Row 8: Ch 2, hdc in each st to last 1 (0, 1, 0, 1) st, sc in next 0 (0, 0, 0, 1) st, turn—30 (31, 31, 33, 33) sts rem.

Row 9: Sl st in first 0 (0, 0, 0, 1) st, ch 2 (2, 2, 1, 1), sc in next 0 (0, 0, 1, 0) st, hdc in each st across, turn—30 (31, 31, 33, 32) sts rem.



Kathryn Martin

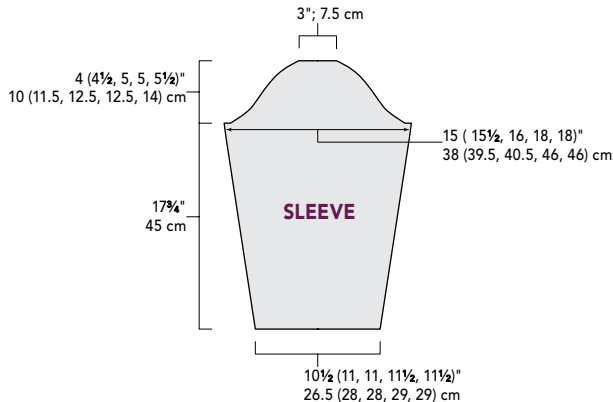
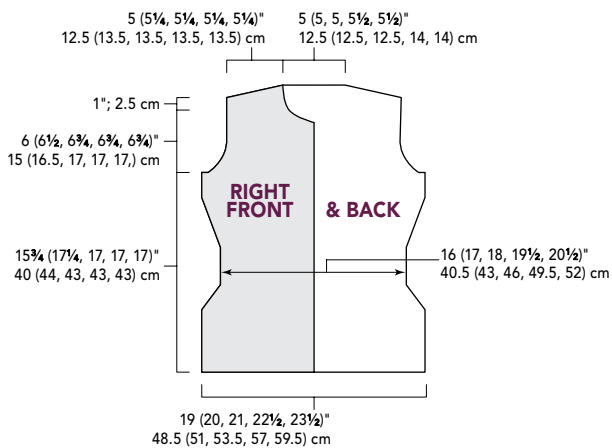

Size 44 1/4" only:

Row 10: Ch 2, hdc in each st to last st, turn, leaving rem st unworked—32 sts.

All sizes:

Work even in patt until armhole measures 5 1/4 (5 3/4, 6, 6, 6)" , ending with a RS row. **Shape neck:**

Row 1: (WS) Sl st in each of first 2 (2, 2, 5, 5) sts, sc in each of next 2 (2, 2, 1, 1) st(s), hdc in each st across, turn—28 (29, 29, 27, 27) sts.

Row 2: Ch 2, hdc in each st to last 5 (5, 5, 3, 3) sts, sc in next st, turn—24 (25, 25, 25, 25) sts.

Row 3: Sl st in each of first 2 sts, ch 1, hdc in each st across, turn—22 (23, 23, 23, 23) sts.

Row 4: Ch 2, hdc in each st to last st, turn, leaving rem st

unworked—21 (22, 22, 22, 22) sts.

Row 5: Sl st in first st, ch 1, hdc in each st across, turn—20 (21, 21, 21, 21) sts.

Row 6: Sl st in each of first 2 (2, 2, 3, 3) sts, sc in each of next 1 (2, 2, 2, 2) st(s), hdc in each st across, turn—18 (19, 19, 18, 18) sts.

Row 7: Ch 2, hdc in each st to last 6 (7, 7, 7, 7) sts, sc in each of next 2 sts, turn, leaving rem sts unworked—14 (14, 14, 13, 13) sts.

Row 8: Sl st in each of first 5 (5, 5, 4, 4) sts, sc in each of next 2 sts, hdc in each st across—9 (9, 9, 9, 9) sts. Fasten off.

Right Front

Work as for left front to armhole. **Shape armhole:**

Row 1: Ch 2, hdc in each st across to last 3 (6, 6, 6, 9) sts, sc in next st, turn, leaving rem sts unworked—36 (35, 37, 40, 39) sts.

Row 2: Sl st in each of first 2 (1, 1, 2, 2) st(s), sc in next st, hdc in each st to end, turn—34 (34, 36, 38, 37) sts.

Row 3: Ch 2, hdc in each st to last 2 sts, sc in next 1 (1, 0, 1, 1) st, turn, leaving rem st(s) unworked—33 (33, 34, 37, 36) sts.

Row 4: Sl st in each of first 1 (1, 1, 2, 1) st(s), ch 1 (1, 1, 1, 0), sc in next 0 (0, 0, 0, 1) st, hdc in each st to end, turn—32 (32, 33, 35, 35) sts.

Row 5: Ch 2, hdc in each st to last 1 (0, 1, 1, 1) st, sc in next 0 (0, 1, 1, 0) st, turn—31 (32, 33, 35, 34) sts.

Row 6: Sl st in first 0 (1, 1, 1, 0) st, ch 2 (1, 1, 0, 1), sc in next 0 (0, 0, 1, 1) st, hdc in each st to end, turn—31 (31, 32, 34, 34) sts.

Row 7: Ch 2, hdc in each st to last 0 (0, 0, 1, 1) st, turn—31 (31, 32, 33, 33) sts.

Row 8: Sl st in first 1 (0, 1, 0, 0) st, ch 1 (2, 1, 2, 1), sc in next 0 (0, 0, 0, 1) st, hdc in each st to end, turn—30 (31, 31, 33, 33) sts.

Row 9: Ch 2, hdc in each st to last 0 (0, 0, 1, 1) st, sc in next 0 (0, 0, 1, 0) st, turn—30 (31, 31, 33, 32) sts.

Size 44 1/4" only:

Row 10: Sl st in first st, ch 1, hdc in each st to end, turn—32 sts.

All sizes:

Work even in patt until armhole measures 5 1/4 (5 3/4, 6, 6, 6)" , ending with a RS row. **Shape neck:**

Row 1: (WS) Ch 2, hdc in each st to last 4 (4, 4, 6, 6) sts,

sc in each of next 2 (2, 2, 1, 1) st(s), turn—28 (29, 29, 27, 27) sts.

Row 2: Sl st in each of first 4 (4, 4, 2, 2) sts, sc in next st, hdc in each st across, turn—24 (25, 25, 25, 25) sts.

Row 3: Ch 2, hdc in each st to last 2 sts, turn—22 (23, 23, 23, 23) sts.

Row 4: Sl st in first st, ch 1, hdc in each st across, turn—21 (22, 22, 22, 22) sts.

Row 5: Ch 2, hdc in each st to last st, turn, leaving rem st unworked—20 (21, 21, 21, 21) sts.

Row 6: Ch 2, hdc in each st to last 3 (4, 4, 5, 5) sts, sc in each of next 1 (2, 2, 2, 2) st(s), turn, leaving rem st(s) unworked—18 (19, 19, 18, 18) sts.

Row 7: Sl st in each of first 4 (5, 5, 5, 5) sts, sc in each of next 2 sts, hdc in each st across, turn—14 (14, 14, 13, 13) sts.

Row 8: Ch 2, hdc in each st to last 7 (7, 7, 6, 6) sts, sc in each of next 2 sts—9 (9, 9, 9, 9) sts. Fasten off.

Sleeves

With MC, ch 44 (46, 46, 48, 48).

Row 1: Hdc in 3rd ch from hook and in each ch across, turn—42 (44, 44, 46, 46) hdc.

Row 2: Ch 2, working through the flo here and throughout, hdc in each st across, turn.

Rep Row 2 for patt. Work a total of 4 rows in MC, 2 rows in CC1, 2 rows in CC2, and then cont in MC only, and at the same time, shape as foll: Work 2 rows even in patt. **Inc row:** Work 2 hdc in each of first and last sts—2 sts inc'd. Rep inc row every 2nd row 0 (0, 0, 2, 2) times, then every 4th row 2 (2, 5, 10, 10) times, then every 6th row 6 (6, 4, 0, 0) times—60 (62, 64, 72, 72) sts. Work even in patt until piece measures 17¾" from beg. **Shape sleeve cap:**

Row 1: Sl st in each of first 3 sts, sc in each of next 2 sts, hdc in each st to last 5 sts, sc in each of next 2 sts, turn—54 (56, 58, 66, 66) sts.

Row 2: Sl st in each of first 3 (4, 4, 4, 4) sts, sc in each of next 2 (1, 1, 1, 2) st(s), hdc in each st to last 5 (5, 5, 5, 6) sts, sc in each of next 2 (1, 1, 1, 2) st(s), turn—48 (48, 50, 58, 58) sts.

Row 3: Sl st in each of first 3 (2, 2, 3, 3) sts, sc in next st, hdc in each st to last 4 (3, 3, 4, 4) sts, sc in next st, turn—42 (44, 46, 52, 52) sts.

Row 4: Sl st in each of first 1 (2, 2, 2, 2) st(s), ch 0 (0, 1, 0, 0), sc in each of next 1 (1, 0, 1, 1) st, hdc in each st to last 2 (3, 2, 3, 3) sts, sc in each of next 1 (1, 0, 1, 1) st, turn—40 (40, 42, 48, 48) sts.

Row 5: Sl st in each of first 2 (1, 1, 1, 2) st(s), ch 0 (0, 0, 0, 1), sc in each of next 1 (1, 1, 1, 0) st, hdc in each st to last 3 (2, 2, 2, 2) sts, sc in each of next 1 (1, 1, 1, 0) st, turn—36 (38, 40, 46, 44) sts.

Row 6: Sl st in each of first 1 (1, 1, 2, 1) st(s), sc in next st, hdc in each st to last 2 (2, 2, 3, 2) sts, sc in next st, turn—34 (36, 38, 42, 42) sts.

Row 7: Sl st in first st, ch 1 (0, 0, 0, 1), sc in next 0 (1, 1, 1, 0) st, hdc in each st to last 1 (2, 2, 2, 1) st(s), sc in next 0 (1, 1, 1, 0) st, turn—32 (34, 36, 40, 40) sts.

Row 8: Sl st in first st, ch 1 (0, 0, 0, 1), sc in next 0 (1, 1, 1, 0) st, hdc in each st to last 1 (2, 2, 2, 1) st(s), sc in next 0 (1, 1, 1, 0) st, turn—30 (32, 34, 38, 38) sts.

Row 9: Sl st in first st, ch 0 (0, 1, 1, 1), sc in next 1 (1, 0, 0, 0) st, hdc in each st across to last 2 (2, 1, 1, 1) st(s), sc in next 1 (1, 0, 0, 0) st, turn—28 (30, 32, 36, 36) sts.

Row 10: Sl st in first 1 (1, 1, 1, 0) st, ch 0 (0, 1, 1, 2), sc in next 1 (1, 0, 0, 0) st, hdc in each st across to last 2 (2, 1, 1, 0) st(s), sc in next 1 (1, 0, 0, 0) st, turn—26 (28, 30, 34, 36) sts.

Row 11: Sl st in each of first 2 (1, 1, 1, 1) st(s), ch 0 (0, 1, 1, 0), sc in next 1 (1, 0, 0, 1) st, hdc in each st to last 3 (2, 1, 1, 2) st(s), sc in next 1 (1, 0, 0, 1) st, turn—22 (26, 28, 32, 34) sts.

Row 12: Sl st in each of first 3 (2, 1, 1, 1) st(s), **size 41¾" only:** ch 1, all sizes: sc in each of next 2 (1, 0, 1, 1) st(s), hdc in each st to last 5 (3, 1, 2, 2) st(s), sc in each of next 2 (1, 0, 1, 1) st(s), **size 37½" only:** fasten off, **rem sizes:** turn—16 (22, 26, 30, 32) sts.

Sizes 39½ (41¾, 44½, 46)" only:

Row 13: Sl st in each of first 2 (1, 2, 1) st(s), sc in each of next 2 (1, 1, 1) st(s), hdc in each st to last 4 (2, 3, 2) sts, sc in each of next 2 (1, 1, 1) st(s), **size 39¾" only:** fasten off, **rem sizes:** turn—18 (24, 26, 30) sts.

Sizes 41¾ (44¼, 46)" only:

Row 14: Sl st in each of first 3 (4, 2) sts, **size 46" only:** ch 1; **sizes 41¾ (44¼)" only:** sc in each of next 2 sts; **all sizes:** hdc to last 5 (6, 2) sts; **sizes 41¾ (44¼)" only:** sc in each of next 2 sts, fasten off; **size 46" only:** turn—18 (18, 26) sts.

Size 46" only:

Row 15: Sl st in each of first 2 sts, sc in next st, hdc in each st to last 3 sts, sc in next st, turn—22 sts.

Row 16: Sl st in each of first 5 sts, sc in each of next 12 sts—12 sts. Fasten off.



Kathryn Martin

row of hdc around the neck, working 1 st in each st around neck, 1 st in each row end where ridges are closer tog, and 2 sts in each row end where ridges are farther apart. Work back and forth in hdc for a total of 13 rows. Fasten off. **Front edging:** With CC1, RS facing, and beg at tip of collar on left front, work 1 row of sc down front of garment, working 1 st in each row-end where ridges are closer tog and 2 sts in each row end where ridges are farther apart. Fasten off. With CC2, RS facing, and beg at tip of collar on left front, work 1 row of sc down front of garment. Fasten off. Work front edging on right front as for left front, beg at bottom corner of right front. Sew in zipper. Block lightly if necessary.

ANNETTE PETAVY lives in Alsace, France. When she's not crocheting, she's building her website at www.annetpetavy.com.

Finishing

Weave in loose ends. With RS tog, sew shoulder seams, side seams, and sleeve seams. Sew sleeves into armholes. **Collar:** With MC and WS facing, and working through the flo here and throughout, work 1



hand
picked
for you

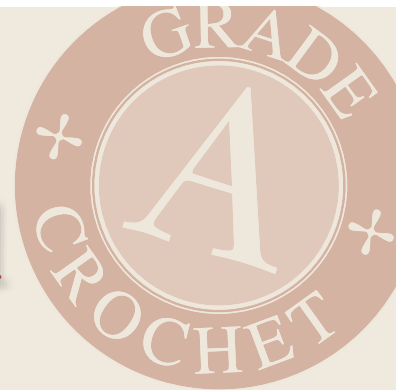

Marcy Smith's 20 most popular patterns

Top designers of the first six years of *Interweave Crochet* showcase their designs and expert advice in one highly sought-after collection.



The Best of Interweave Crochet
A Collection of Our Favorite Designs
Marcy Smith
160 pages, 8 1/2 x 9, \$24.95, pb
ISBN: 978-1-59668-302-0

 **INTERWEAVE**
interweavestore.com

Wool Bam Boo Cardigan

design by
Kristen TenDyke

Originally published in
Interweave Crochet, Fall 2007

TUNISIAN KNIT STITCH creates a fabric that's denser and less stretchy than fabric knitted with stockinette stitch. This simple technique combined with full-fashion shaping creates a warm, form-flattering cardigan. Lace trim at the cuffs and hem add a feminine touch.

FINISHED SIZE 30 (34, 38, 42, 46)" bust circumference, buttoned. Cardigan shown measures 34".

YARN Classic Elite Wool Bam Boo (50% wool, 50% bamboo; 118 yards [108 m]/1¾ oz [50 g]); #: #1648, denim blue, 14 (15, 17, 19, 21) balls.

HOOK SIZE G/6 (4 mm) 22" long flexible Afghan (Tunisian) hook and size E/4 (3.5 mm). Adjust hook sizes if necessary to obtain the correct gauge.

NOTIONS Yarn needle; ½" buttons, 7; removable marker (m).

GAUGE 23 sts and 22 rows = 4" in Tunisian knit stitch on larger hook. The row gauge consists of forward pass and return pass counted as 1 row. Be sure to wash your swatch.

SKILL LEVEL Intermediate.



Kathryn Martin

Stitch Guide

Tunisian knit (Tks)

Foundation Forward Pass (FwdP): Insert hook through the ridge lp on the backside of the 2nd ch, yo, pull up a lp, leave lp on hook, pull up a lp through ridge lp in each ch across (first lp counts as first st).

Foundation Return Pass (RetP): Yo and pull through first lp on hook (1 ch made), *yo, draw through 2 lps on hook; rep from * until 1 lp rem; do not turn.

Row 1 Forward Pass (FwdP): Pull up a lp in each stitch across as foll: Beg with 2nd st (existing lp counts as first st) *insert bet next vertical bars under horizontal strands, yo, draw up a lp, leave lp on hook; rep from * in each st across.

Row 1 Return Pass (RetP): Work as for Foundation RetP. Rep Row 1 FwdP and RetP for patt (counts as 1 row).

Right-Slant Dec (RSdec): Sk next st, insert hook in next st, pull forward the back lp, insert hook in skipped st, yo and draw through lp.

Left-Slant Dec (LSdec): Insert hook in next st, pull forward front lp, insert hook in next st, yo and draw through lp.

Make 1 Inc (M1): Insert hook between next 2 sts, draw up a lp.

Picot Edge: (multiple of 3 sts)

*Sl st in the next st, ch 2, sl st in same st, sl st in next st; rep from * across.

Notes

When working Tunisian knit stitch, do not turn the work; all work is done on the RS.

Back

With larger hook, ch 86 (98, 109, 121, 132).

Work Foundation FwdP and RetP (see Stitch Guide) across ch—86 (98, 109, 121, 132) sts. Work Row 1 FwdP and RetP (see Stitch Guide) even for 2 rows, end with RetP completed. **Shape waist:**

Row 1 FwdP: (dec row) *Tks (see Stitch Guide) in next st (2 lps on hook), RSdec (see Stitch Guide), Tks to last 4 sts, LSdec (see Stitch Guide), Tks rem 2 sts; RetP work even—84 (96, 107, 119, 130) sts.

Work even in Tks for 2 (3, 4, 5, 5) more rows, end with RetP completed; rep from * 3 more times—78 (90, 101, 113, 124) sts.

Next row: (inc row) Tks in next st (2 lps on hook), M1 (see Stitch Guide), Tks to last 2 sts, M1, Tks in rem 2 sts; RetP work even—80 (92, 103, 115, 126) sts. Work 9 rows even, end with RetP completed; rep from * 3 more times—86 (98, 109, 121, 132) sts. Tks even until piece measures 10½ (11, 11½, 12, 12½)" from beg, end with RetP completed. Fasten off. **Shape armholes:**

Row 1 FwdP: Join yarn with sl st to 6th st from beg of row, work first Tks in 6th st, Tks to last 5 sts; RetP work even—76 (88, 99, 111, 122) sts.

TUNISIAN KNIT STITCH (TKS)

is a variation of Tunisian crochet that mimics the look of knitted stockinette stitch. Tunisian crochet is made using a very long crochet hook. Each row is worked in two steps—a forward pass and a return pass—without turning; the RS is always facing.

Start with a foundation ch equal to the number of sts required, turn.

Foundation Forward Pass: Insert hook in 2nd ch from hook, yo, pull up a lp, leaving lp on hook, *insert hook in next ch, yo, pull up a lp, leaving lp on hook; rep from * to end of row. There is one lp on hook for every ch. Do not turn work.

Foundation Return Pass: Ch 1, *yo, draw through first 2 lps on hook (Figure 1); rep from * to end of row, 1 lp rem on hook. This lp

counts as first st of next row.

Row 1, Forward Pass: Sk first vertical bars, *insert hook between next vertical bars under horizontal strands (Figure 2), yo, pull up a lp, leaving lp on hook; rep from * to end of row. There is one lp on hook for every st. Do not turn work.

Row 1, Return Pass: Rep as for Foundation Return Pass (Figure 3).

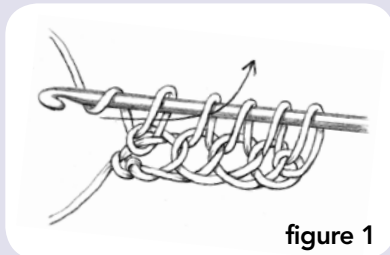

figure 1

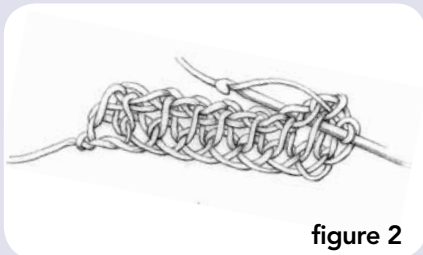

figure 2

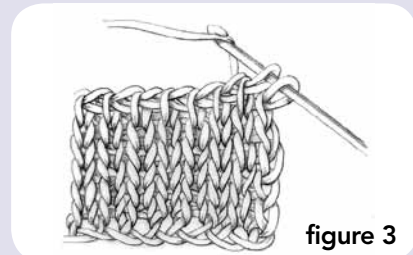

figure 3

Row 2 FwdP: (dec row) Tks in next st (2 lps on hook), RSdec, Tks to last 4 sts, LSdec, Tks in rem 2 sts; RetP work even—74 (86, 97, 109, 120) sts.

Row 3: Tks across.

Rep Rows 2–3 zero (three, five, five, five) more times—74 (82, 89, 101, 110) sts, then work Row 2 zero (one, two, four, seven) more times—74 (78, 83, 91, 96) sts. Work even until armhole measures 7¼ (7¾, 8¼, 8¾, 9¼)" from beg of shaping, end with RetP completed. **Shape neck and right shoulder:** Note: Unworked sts will remain on hook until last row.

Row 1 FwdP: 1 lp on hook (counts as st here and throughout), Tks in next 28 (30, 31, 33, 35) sts; work RetP for 26 (28, 29, 30, 32) sts.

Row 2 FwdP: Tks in next 20 (22, 23, 24, 26) sts; RetP 18 (20, 21, 21, 23) sts.

Row 3 FwdP: Tks in next 14 (16, 17, 17, 19) sts; RetP 12 (14, 15, 15, 16) sts.

Row 4 FwdP: Tks in next 9 (11, 12, 12, 13) sts; RetP 8 (9, 10, 10, 10) sts.

Row 5 FwdP: Tks in next 5 (6, 7, 7, 7) sts; RetP 4 (4, 5, 5, 5) sts.

Beg Left Shoulder:

Row 6 FwdP: Work across row to last 3 (3, 3, 4, 4) sts; RetP 21 (23, 24, 25, 27) sts.

Row 7 FwdP: Tks in next 17 (19, 20, 20, 22) sts; RetP 15 (17, 18, 18, 20) sts.

Row 8 FwdP: Tks in next 11 (13, 14, 14, 15) sts; RetP 10 (12, 13, 13, 14) sts.

Row 9 FwdP: Tks in next 7 (8, 9, 9, 9) sts; RetP 6 (7, 8, 8, 8) sts.

Row 10 FwdP: Tks in next 3 (3, 4, 4, 4) sts; RetP 2 (2, 3, 3, 3) sts.

Row 11 FwdP: Tks to end of row; work RetP even on all sts. Fasten off.

Left Front

With larger hook, ch 43 (49, 55, 60, 66). Work Tks Foundation FwdP and RetP across ch—43 (49, 55, 60, 66) sts. Work even in Tks for two rows, ending with RetP completed. **Shape Waist:**

Row 1 FwdP: (dec row) Tks in next st (2 lps on hook) work RSdec, Tks to end; RetP work even—42 (48, 54, 59, 65) sts.

Work even in Tks for 2 (3, 4, 5, 5) rows; rep from * 3 more times—39 (45, 51, 56, 62) sts. **Next Row FwdP:** (inc

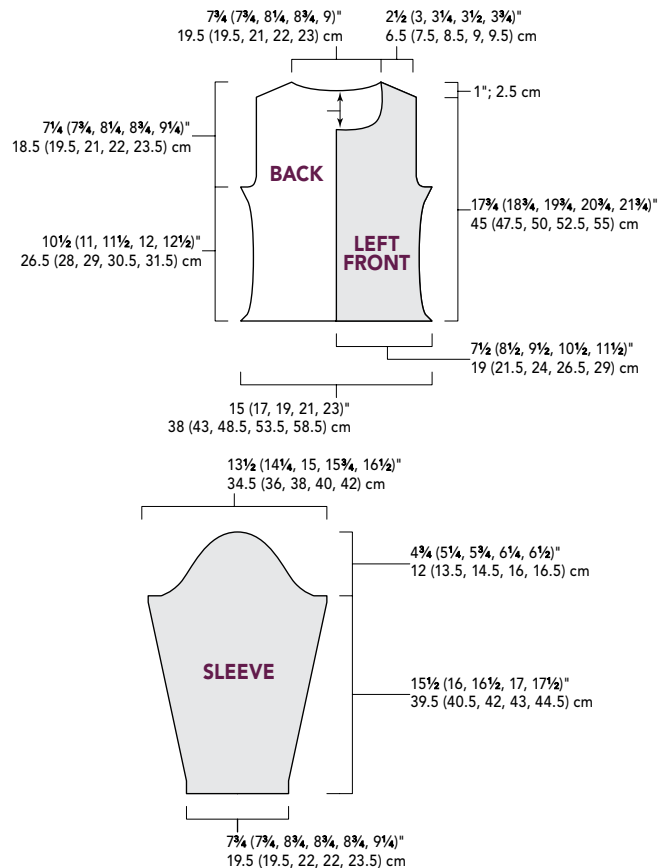

row) Tks in next st (2 lps on hook), M1, Tks to end of row; work RetP even—40 (46, 52, 57, 63) sts. Work 9 rows even; rep from * 3 more times—43 (49, 55, 60, 66) sts. Work even until piece measures 10½ (11, 11½, 12, 12½)" from beg, end with RetP completed. Fasten off. **Shape Armholes:**

Row 1 FwdP: Join yarn with sl st to 6th st from beg of row, work first Tks in 6th st, Tks across row; work RetP even—38 (44, 50, 55, 61) sts.

Row 2 FwdP: (dec row) Tks in next st (2 lps on hook), RSdec, Tks to end; RetP work even—37 (43, 49, 54, 60) sts.

Row 3: Work even in Tks.

Rep Rows 2–3 zero (three, five, five, five) more times—37 (40, 44, 49, 55) sts, then work Row 2 zero (one, two, four, seven) time(s)—37 (39, 42, 45, 48) sts. Work even until armhole measures 4½ (5, 5½, 6, 6½)" from beg of shaping, end with RetP completed. **Shape Neck:**

Row 1 FwdP: Tks to last 8 (8, 7, 7, 7) sts; work RetP even—29 (31, 35, 38, 41) sts.

Row 2 FwdP: Tks 27 (29, 32, 35, 38) sts (includes beg lp here and throughout this section); work RetP even.

Row 3 FwdP: Tks 25 (27, 29, 32, 35) sts; work RetP even.

Row 4 FwdP: Tks 23 (25, 26, 29, 32) sts; work RetP even.

Row 5 FwdP: (Dec) Tks to last 4 sts, work LSdec, Tks to end; work RetP even—22 (24, 25, 28, 31) sts.

Rep Row 5 four (four, four, six, three) more times—18 (20, 21, 22, 28) sts. **Next row:** Work even in Tks. **Next**

row FwdP: (dec row) Tks to last 4 sts, work LSdec, Tks to end; work RetP even. **Next row:** Work even in Tks. Work last two rows 3 (3, 3, 2, 6) more times. Work even until armhole measures same as back to shoulder shaping. **Shape Shoulder:** Note: Unworked sts will rem on hook until last row.

Row 1 FwdP: Tks 14 (16, 17, 19, 21) sts (includes lp at beg of row here and throughout); RetP work 12 (14, 15, 16, 18) sts.

Row 2 FwdP: Tks 12 (14, 15, 16, 18) sts; RetP work 9 (11, 12, 12, 14) sts.

Row 3 FwdP: Tks 9 (11, 12, 12, 14) sts; RetP work 6 (8, 9, 9, 10) sts.

Row 4 FwdP: Tks 6 (8, 9, 9, 10); RetP work 4 (5, 6, 6, 6) sts.

Row 5 FwdP: Tks 4 (5, 6, 6, 6) sts; RetP work 2 (2, 3, 3, 3) sts.

Row 6 FwdP: Tks 2 (2, 3, 3, 3) sts; RetP work even across all sts on hook. Fasten off.

Right Front

With larger hook, ch 43 (49, 55, 60, 66).

Work Tks Foundation FwdP and RetP across ch—43 (49, 55, 60, 66) sts. Work even for 2 rows, end with RetP completed. **Shape Waist:**

Row 1 FwdP: (dec row) Tks to last 4 sts, work LSdec, Tks to end; RetP work even—42 (48, 54, 59, 65) sts.

Work even for 2 (3, 4, 5, 5) rows; work last 3 (4, 5, 6, 6) rows 3 more times—39 (45, 51, 56, 62) sts. **Next**

Row: (inc row) Tks to last 2 sts, M1, Tks to end; work RetP even. Work 9 rows even. Work last 10 rows 3 more times—43 (49, 55, 60, 66) sts. Work even until piece measures 10½(11, 11½, 12, 12½)", end with RetP completed. **Shape Armholes:**

Row 1 FwdP: Tks to last 5 sts; work RetP even—38 (44, 50, 55, 61) sts.

Row 2 FwdP: (dec row) Tks to last 4 sts, LSdec, Tks to end; RetP work even—37 (43, 49, 54, 60) sts.

Row 3: Work even in Tks.

Rep Rows 2–3 zero (three, five, five, five) more times—37 (40, 44, 49, 55) sts, then work Row 2 zero (one, two, four, seven) time(s)—37 (39, 42, 45, 48) sts. Work even until armhole measures 4½ (5, 5½, 6, 6½)" from beg of shaping, end with RetP completed. **Shape**

Neck:

Row 1 FwdP: Join yarn with sl st to the 9th (9th, 8th, 8th, 8th) st, work first Tks st in same st, Tks to end; RetP work even—29 (31, 35, 38, 41). Fasten off.

Row 2 FwdP: Join yarn with sl st to 3rd (3rd, 4th, 4th, 4th) st, work first st in same st, Tks to end; RetP work even—27 (29, 32, 35, 38) sts. Fasten off.

Rows 3–4: Rep Row 2—23 (25, 26, 29, 32) sts.

Row 5 FwdP: (dec row) Tks next st (2 lps on hook), work RSdec, Tks to end; RetP work even—22 (24, 25, 28, 31) sts.

Rep Row 5 four (four, four, six, three) more times—18 (20, 21, 22, 28) sts. **Next row:** Work even in Tks.

Next row: (dec row) Tks next st (2 lps on hook),

work RSdec, Tks to end; RetP work even. **Next row:** Work even in Tks. Rep last 2 rows 3 (3, 3, 2, 6) more times—14 (16, 17, 19, 21) sts. Work even until armhole measures same as back to shoulder shaping.

Shape Shoulder:

Row 1 FwdP: Tks in next 12 (14, 15, 16, 18) sts (includes first lp on hook here and throughout); RetP work even.

Row 2 FwdP: Tks in next 9 (11, 12, 12, 14) sts; work RetP even.

Row 3 FwdP: Tks in next 6 (8, 9, 9, 10) sts; work RetP even.

Row 4 FwdP: Tks in next 4 (5, 6, 6, 6) sts; work RetP even.

Row 5 FwdP: Tks in next 2 (2, 3, 3, 3) sts; work RetP even.

Row 6 FwdP and RetP: Work even. Fasten off.

Sleeves

With larger hook, ch 44 (44, 50, 50, 54). Work Tks Foundation FwdP and RetP across ch—44 (44, 50, 50, 54) sts. Work even for 2 rows, end with RetP completed. **Shape Sleeve:**

Row 1 FwdP: (inc row) Tks in next st (2 lps on hook), M1, Tks across row to last 2 sts, M1, Tks to end; RetP work even—46 (46, 52, 52, 56) sts.

Rows 2 and 3: Work even.



Kathryn Martin

Rep Rows 1–3 four (eleven, four, eleven, five) more times—54 (60, 68, 74, 66) sts. Cont in Tks across all sts working Row 1 every 5th row 12 (7, 13, 8, 14) times—78 (82, 86, 90, 94) sts. Work even until piece measures 15½ (16, 16½, 17, 17½)" from beg, end with RetP completed. Fasten off. **Shape Cap:**

Row 1 FwdP: Join yarn with sl st to 6th st from beg of row, work first Tks st in same st, Tks across to last 5 sts; RetP work even—68 (72, 76, 80, 84) sts rem.

Row 2 FwdP: (dec row) Tks next st (2 lps on hook), work RSdec, Tks to last 4 sts, work LSdec, Tks to end; RetP work even—66 (70, 74, 78, 82) sts.

Row 3: Work even.

Rep Rows 2–3 two (two, four, four, four) more times—62 (66, 66, 70, 74) sts, then work Row 2 only 20 (22, 22, 24, 26) times, end with RetP completed—22 sts rem. Fasten off. **Next row FwdP:** Join yarn with sl st to 5th st from beg of row, work first Tks in same st, Tks in next 13 sts; RetP work even—14 sts. Fasten off.

Finishing

Block pieces to measurements. Sew shoulder seams and side seams. **Sleeve Trim:** With smaller hook and RS facing, join yarn with sl st to right edge of sleeve lower edge.

Row 1: Ch 1 (counts as first sc) work 42 (42, 50, 50, 58) sc across, turn—43 (43, 51, 51, 59) sc.

Row 2: Ch 1, sc in first sc, ch 3 (counts as dc, ch 1), sk next sc, dc in next sc, *ch 1, sk next sc, dc in next sc; rep from * across, turn.

Row 3: Ch 1, sc in first ch-1 sp, *ch 5, sk next ch-1 sp, sc in next ch-1 sp; rep from * across, turn.

Row 4: Ch 1, *7 sc in next ch-5 sp; rep from * across, turn.

Row 5: Ch 5, sk 3 sc, sc in next sc, *ch 5, sk next 6 sc, sc in next sc; rep from * to last 3 sc, ch 3, dc in last sc, turn.

Row 6: Ch 1, sc in ch-3 sp, *ch 5, sc in next ch-5 sp; rep from * across. Fasten off.

Body Trim: With smaller hook and RS facing, join yarn with sl st to bottom corner of left front.

Row 1: Ch 1 (counts as first sc), sc 45 (47, 49, 51, 52) across left front to seam; sc 87 (91, 95, 99, 105) across back to seam; sc 45 (47, 49, 51, 52) across right front—177 (185, 193, 201, 209) sts, turn.

Rows 2–6: Work as for sleeve trim. Fasten off.

Buttonbands and neck trim: Place markers for buttonholes on right front, the first at the beg of trim, the last at the top neck corners, space rem 5 evenly bet. With smaller hook and RS facing, attach yarn to bottom corner of right-front trim. Ch 1 (counts as first sc), sc up right front to corner, 3 sc in corner st, sc around neck edge to left-front corner, 3 sc in corner st, sc down left front, turn. **Next row:** Work 4 rep of Picot Edge (see Stitch Guide), sc up left front to 3 corner sts, Picot Edge around neck sts to 3 right-front corner sts, turn. **Buttonhole:** Ch 4, skip next 2 sc, work Picot Edge st to next m; rep buttonhole at each marker, ending with Picot Edge st to end. Fasten off. Sew sleeve seams; sew sleeves into armholes. Weave in loose ends and wet-block.

KRISTEN TENDYKE lives in Wakefield, Massachusetts, with her boyfriend, James; her kitty, Jelly; and her two birds, Tweak and Omar. She works for Classic Elite Yarns as a graphic designer and tech editor. Her designs have appeared in books, magazines, and yarn-company collections.

Glossary

Abbreviations

beg	begin(s); beginning	rem	remain(s); remaining
bet	between	rep	repeat; repeating
blo	back loop only	rev sc	reverse single crochet
CC	contrasting color	rnd(s)	round(s)
ch(s)	chain	RS	right side
cm	centimeter(s)	sc	single crochet
cont	continue(s); continuing	sk	skip
dc	double crochet	sl	slip
dec(s)('d)	decrease(s); decreasing; decreased	sl st	slip(ped) stitch
est	established	ss	slip stitch
fdc	foundation double crochet	sp(s)	space(es)
flo	front loop only	st(s)	stitch(es)
fol	follows; following	tch	turning chain
fsc	foundation single crochet	tog	together
g	gram(s)	tr	treble crochet
hdc	half double crochet	WS	wrong side
inc(s)('d)	increase(s); increasing; increased	yd	yard
k	knit	yo	yarn over hook
lp(s)	loop(s)	*	repeat starting point
MC	main color	**	repeat all instructions between asterisks
m	marker	()	alternate measurements and/or instructions
mm	millimeter(s)	[]	work bracketed instructions a specified number of times
patt(s)	pattern(s)		
pm	place marker		
p	purl		

Glossary

Crochet Gauge

To check gauge, chain 30 to 40 stitches using recommended hook size. Work in pattern stitch until piece measures at least 4" (10 cm) from foundation chain. Lay swatch on flat surface. Place a ruler over swatch and count number of stitches across and number of rows down (including fractions of stitches and rows) in 4" (10 cm). Repeat two or three times on different areas of swatch to confirm measurements. If you have more stitches and rows than called for in instructions, use a larger hook; if you have fewer, use a smaller hook. Repeat until gauge is correct.

Crochet Chain (ch)

Make a slipknot on hook. Yarn over hook and draw it through loop of slipknot. Repeat, drawing yarn through the last loop formed.

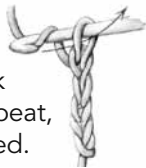

Slip Stitch Crochet (sl st)

Insert hook into stitch, yarn over hook and draw loop through stitch and loop on hook.



Double Crochet (dc)

*Yarn over, insert hook into a stitch, yarn over and pull a loop through stitch (three loops on hook; Figure 1), yarn over and draw it through two loops (Figure 2), yarn over and draw it through the remaining two loops (Figure 3). Repeat from *.

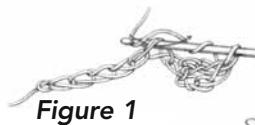

Figure 1



Figure 2



Figure 3

Treble Crochet (tr)

*Wrap yarn around hook two times, insert hook into a stitch, yarn over and pull a loop through (four loops on hook; Figure 1), yarn over and draw it through two loops (Figure 2), yarn over and draw it through the next two loops, yarn over and draw it through the remaining two loops (Figure 3). Repeat from *.

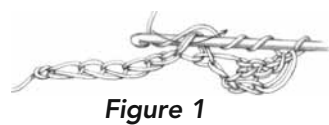

Figure 1

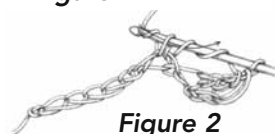

Figure 2



Figure 3

Single Crochet (sc)

Insert hook into a stitch, yarn over hook and draw a loop through stitch, yarn over hook (Figure 1) and draw it through both loops on hook (Figure 2).



Figure 1



Figure 2

Single Crochet Two Together (sc2tog)

Insert hook in next stitch, yarn over, pull up loop (2 loops on hook, Figure 1), insert hook in next stitch, yarn over, pull up loop (3 loops on hook), yarn over and draw through all 3 loops on hook (Figure 2)—1 stitch decreased (Figure 3).



Figure 1



Figure 2



Figure 3

Reverse Single Crochet (rev sc)

Working from left to right, insert crochet hook into an edge stitch and pull up a loop, yarn over and draw this loop through the first one to join. *Insert hook into next stitch to right (Figure 1), pull up a loop, yarn over (Figure 2), and draw through both loops on hook (Figure 3). Repeat from *.



Figure 1

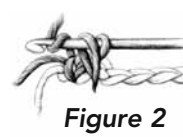

Figure 2

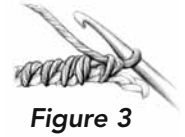

Figure 3

Knitting Basics

From casting on to binding off, here are step-by-step instructions to guide you through the knitting in these special crochet + knit projects.

ABBREVIATIONS

CO	cast on
k	knit
k1f&b	knit into front and back of same st
k2tog	knit two stitches together
kwise	knitwise
p	purl
p1f&b	purl into front and back of same st
p2tog	purl two stitches together
pssso	pass slipped stitch over
p2sso	pass two slipped stitches over
pwise	purlwise
rev St st	reverse stockinette stitch
rib	ribbing
sl st	slip stitch (sl 1 st pwise unless otherwise indicated)
ssk	slip 1 kwise, slip 1 kwise, k2 sl sts tog tbl (decrease)
ssp	slip 1 kwise, slip 1 kwise, p2 sl sts tog tbl (decrease)
St st	stockinette stitch
tbl	through back loop
wyb	with yarn in back
wyf	with yarn in front

Knit Stitch (k)

With yarn held to the back of the work, insert the right needle into the first stitch on the left needle from bottom of the stitch to top and from the front of the stitch to the back. Wrap yarn around right-needle tip counterclockwise. Slip the right needle back through the stitch, carrying the wrapped yarn with it, then drop the worked stitch off the left needle. Gently tighten the yarn. One knit stitch completed on right needle.



Purl Stitch (p)

With yarn held to the front of the work, insert the right needle into the first stitch on the left needle from the top of the stitch to the bottom and from the back of the stitch to the front. Wrap the yarn around the right-needle tip counterclockwise. Draw the right needle back through the stitch carrying the wrapped yarn with it, drop the worked stitch of the left needle and gently tighten the yarn. One purl stitch completed on right needle.

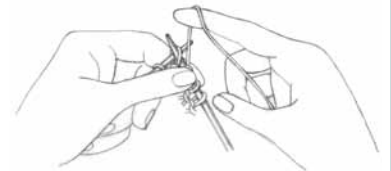

Cable Cast-On

Begin with a slipknot and one knitted cast-on stitch if there are no established stitches. Insert right needle between first two stitches on left needle (Figure 1). Wrap yarn as if to knit. Draw yarn through to complete stitch (Figure 2) and slip this new stitch to left needle as shown (Figure 3).



Figure 1



Figure 2



Figure 3

Continental (Long-Tail) Cast-On

Leaving a long tail (about ½" to 1" for each stitch to be cast on), make a slipknot and place on right needle. Place thumb and index finger of left hand between yarn ends so that working yarn is around index finger and tail end is around thumb. Secure ends with your other fingers and hold palm upward, making a V of yarn (Figure 1). Bring needle up through loop on thumb (Figure 2), grab first strand around index finger with needle, and go back down through loop on thumb (Figure 3). Drop loop off thumb and, placing thumb back in V configuration, tighten resulting stitch on needle (Figure 4).

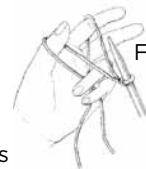

Figure 1



Figure 2



Figure 3



Figure 4

Knitting Basics

Backward-Loop Cast-On

*Loop working yarn and place it on needle backward so that it doesn't unwind. Repeat from *.



Purl 2 together (p2tog)

Purl two stitches together as if they were a single stitch.

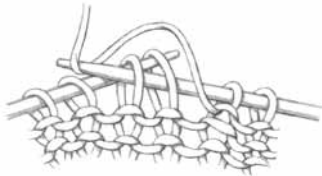

Knit 2 together (k2tog)

Knit two stitches together as if they were a single stitch.

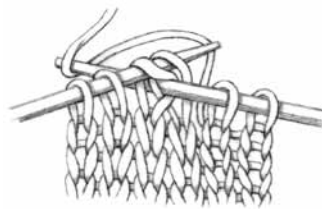

Raised (M1) Increases

With left needle tip, lift strand between needles from front to back (Figure 1). Knit lifted loop through the back (Figure 2).

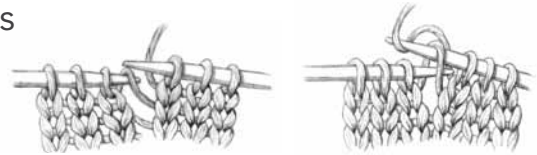

Figure 1

Figure 2

Short-Rows: Wrapping a Stitch

Work to turn point, slip next stitch purlwise to right needle. Bring yarn to front (Figure 1). Slip same stitch back to left needle (Figure 2). Turn work and bring yarn in position for next stitch, wrapping the stitch as you do so. Note: Hide wraps in a knit stitch when right side of piece is worked in a knit stitch. Leave wrap if the purl stitch shows on right side. Hide wraps as follows: *Knit stitch:* On right side, work to just before wrapped stitch. Insert right needle from front, under the wrap from bottom up, and then into wrapped stitch as usual. Knit them together, making sure new stitch comes out under wrap. *Purl stitch:* On wrong side, work to just before wrapped stitch. Insert right needle from back, under wrap from bottom up, and put on left needle. Purl them together.



Figure 1



Figure 2

Standard Bind-Off (BO)

Knit the first stitch, *knit the next stitch (2 stitches on right needle), insert left needle tip into first stitch on right needle (Figure 1) and lift this stitch up and over the second stitch (Figure 2) and off the needle (Figure 3). Repeat from * for the desired number of stitches.

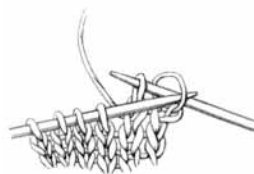

Figure 1

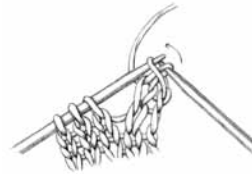

Figure 2



Figure 3