

HOW TO CROCHET SQUARES,
CIRCLES AND CROCHET MOTIFS:

FREE
Crochet Motif
Patterns



HOW TO CROCHET SQUARES, CIRCLES AND CROCHET MOTIFS:

FREE Crochet Motif Patterns

THE BUILDING BLOCKS OF CROCHET, MOTIFS PERFECTLY COMBINE STRUCTURE AND LACE, AND ARE THE PERFECT COMPONENTS FOR SWEATERS, SCARVES, SHAWLS, AND MORE. Crochet motifs can also be the perfect technique for crocheting squares, hexagons, circles, and more.

With this free collection of patterns, I wanted to highlight both projects that used crochet motifs in classic construction styles as well as projects that highlight motifs in unusual ways. You will find traditional shawls comprised of lacy and detailed crochet motifs. A gorgeous afghan highlights the crochet motif in a new and fun way.

The **Cabine de Dentelle** by Annette Petavy is a log cabin inspired design borders a lacy crochet motif creating larger square motifs that combine to create a beautiful afghan that highlights both the geometrical and lace qualities of crochet.

The **Serene Box Pleat Top** by Kristin Omdahl is a sophisticated and flattering top with clever shaping. Worked in lace-weight yarn, the rows of strips of motifs in this tank top have beautiful drape. A v-shaped lace insert of a second motif highlights the possibilities of motifs to create either columns or lace.

Designed to emulate the frothy swirls of the ocean, the **Katrina Shawl** by Lisa Pflug uses two strands of lace-weight yarn to create a gradual color shift across the breadth of the shawl. The soft haze of the mohair adds comforting warmth. The motifs are joined as you go, creating the central panels first, then adding the outer motifs.

Large crochet motifs create the **Ring Around the Posie** by Tammy Hildebrand. This top is created from six strips for a total of eighteen simple motifs. Style it over a simple cami in a contrasting color to create a trendy, relaxed look or pair it with a matching silk cami for a more sophisticated look.

A riot of colors make **Carmen's Jazz Scarf** by Sue B. Balcom the perfect stash busting accessory. Exploded crochet motifs are joined as you go to create a wide scarf that is sure to be a statement piece. For a more delicate accessory, try working this motif pattern in a DK or fingering weight yarn.

Whether you want to explore the construction of crochet motifs, learn how to join motifs as you go, or discover multiple ways to incorporate motifs into gorgeous projects, you will find the perfect crochet motif pattern in How to Crochet Squares, Circles and Crochet Motifs: Free Crochet Motif. We would love to see your work; share your pictures in the Crochet Member Gallery.

Best wishes



P.S. For another fabulous crochet motif pattern, check out the Larger Than Life Bag by Cecily Keim in Crochet Bags and Purses: 7 Free Crochet Bag Patterns or the Magic Carpet Blanket by Melisa Darnieder in Free Baby Crochet Patterns from Crochet Me: 9 Free Crochet Patterns for Babies.

- 1 **Cabine de Dentelle** page 3
- 2 **Serene Box Pleat Top** page 6
- 3 **Katrina Shawl** page 11
- 4 **Ring Around the Posie** page 13
- 5 **Carmen's Jazz Scarf** page 17

Abbreviations and Glossary page 20

crochetme

HOW TO CROCHET SQUARES, CIRCLES
AND CROCHET MOTIFS: FREE CROCHET
MOTIF PATTERNS

A CROCHET ME E-BOOK EDITED BY
Toni Rexroat

EDITORIAL STAFF
EDITOR CROCHET ME Toni Rexroat

CREATIVE SERVICES

PRODUCTION DESIGNER Nichole Mulder

PHOTOGRAPHY As noted

ILLUSTRATION Gayle Ford

©F+W Media, Inc. All rights reserved. F+W Media grants permission for any or all pages in this issue to be copied for personal use.



PHOTO BY JOE HANCOCK

cabine de dentelle afghan

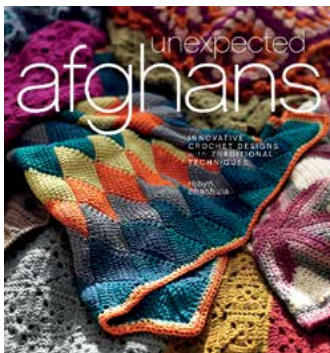

I've always been fascinated by the log-cabin motif and how its simplicity can be used as a backdrop for sophisticated compositions. The lacy flower is, in a way, the essence of crochet to me. In this afghan, I tried to put them together, to see how it turned out. In my opinion, it worked! ● **BY ANNETTE PETAVY**

MATERIALS

Yarn DK weight (#3 Light).

Shown Filatura di Crosa Zara (100% merino superwash; 137 yd [125 m]/ 1.75 oz [50 g]): 4 balls #1396 off white (MC), 4 balls #1494 light grey (CC1), 4 balls #1468 charcoal grey (CC2), 1 ball #1451 oatmeal (CC3).

Hook 7 (4.5 mm) or size needed to obtain gauge.

Notions Tapestry needle, straight pins for blocking.

GAUGE

15 dc and 8 rows = 4"
(10 cm) in dc. Square =
7" × 7" (18 × 18 cm).

FINISHED SIZE

49" × 49" (124.5 × 124.5 cm).

NOTES

This design relies on the contrast between the solid dc "logs"—inspired by the traditional log cabin quilt design—and the airy flower motif. To achieve this contrast, the flower needs to be quite heavily blocked. I recommend pinning out the finished squares to measurements and ironing them (with a light hand) on the wrong side of the fabric.

SPECIAL STITCHES

4 Treble Crochet Cluster (4tr-cl) *Yo twice, insert hook in indicated sp, yo and pull up lp, [yo and draw through 2 lps on hook] 2 times; rep from * 3 times in same sp, yo and pull through rem 5 lps on hook.

5 Treble Crochet Cluster (5tr-cl) *Yo, insert hook in indicated sp, yo and pull up lp, [yo and draw through 2 lps on hook] 2 times; rep from * 4 times in same sp, yo and pull through rem 6 lps on hook.

pattern

SQUARE (make 16)

With MC, ch 5, sl st in first ch to form a ring.

RND 1 (RS): Ch 1 (does not count as a st), 12 sc in ring, sl st in first sc to join—12 sc.

RND 2: Ch 7 (counts as tr, 3 ch), [tr in next sc, ch 3] 11 times, sl st in 4th ch of

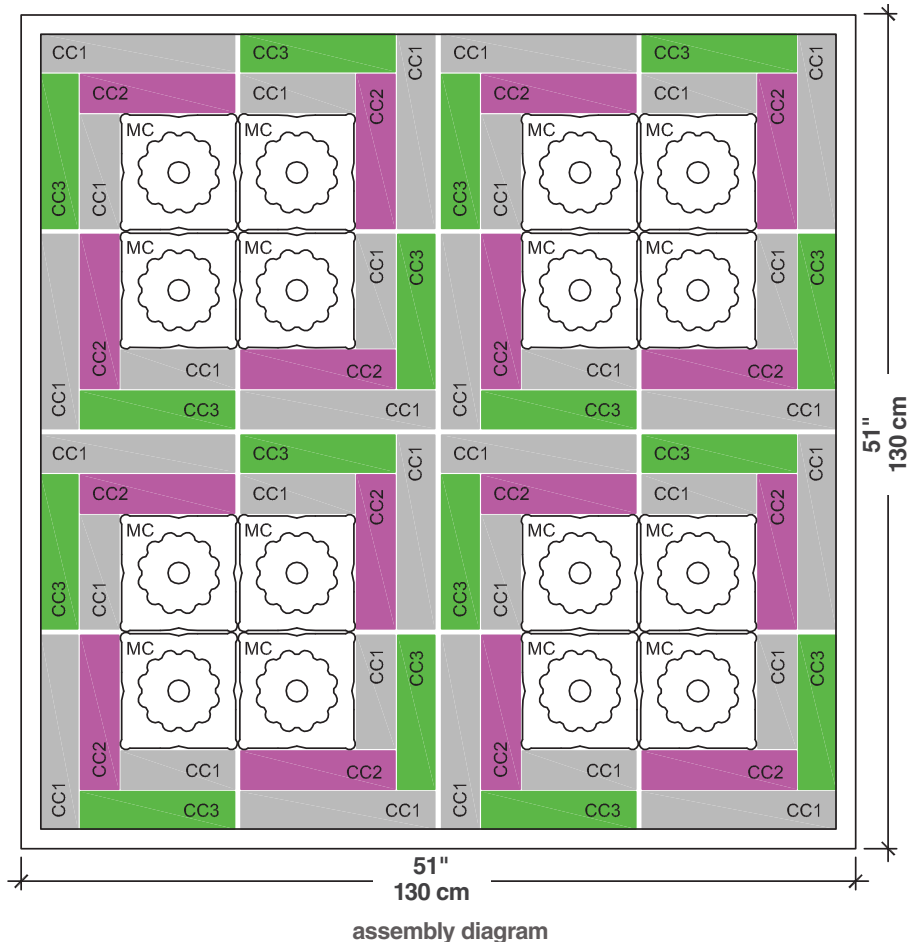

- beg ch-7 to join—12 tr, 12 ch-3 sps.
- RND 3:** Sl st in ch-3 sp, ch 4 (counts as tr), 4tr-cl (see Special Stitches) in same ch-3 sp, [ch 6, 5tr-cl (see Special Stitches) in next ch-3 sp] 11 times, ch 3, dc in 4tr-cl at beg of rnd to join—12 tr clusters, 12 ch-6 sps.
- RND 4:** Ch 8 (counts as dc, ch 5), 5 dc around dc at end of previous round, *ch 2, sc in ch-6 sp, ch 7, sc in next ch-6 sp, ch 2, (5 dc, ch 5, 5 dc) in next ch-6 sp; rep from * 2 times, ch 2, sc in next ch-6 sp, ch 7, sc in next ch-6 sp, ch 2, 4 dc in next ch-6 sp, sl st in 3rd ch of beg ch-8 to join—4 "corners" with (5 dc, ch 5, 5 dc), 4 sides with (2-ch sp, sc, 7-ch sp, sc, 2-ch sp).
- RND 5:** Ch 3 (counts as dc), (3 dc, ch 5, 3 dc) in ch-5 sp, dc in each of next 5 dc, *ch 5, sc in ch-7 sp, ch 5, dc in next 5 dc,

(3 dc, ch 5, 3 dc) in ch-5 sp, dc in next 5 dc; rep from * 2 times, ch 5, sc in next ch-7 sp, ch 5, dc in next 4 dc, sl st in 3rd ch of beg ch-8 to join. Fasten off.

LOG 1

ROW 1: With RS facing, join CC1 with sl st in any corner ch-5 sp, ch 3 (counts as dc), dc in same sp, dc in next 8 dc, 4 dc in next ch-5 sp, dc in next sc, 4 dc in next ch-5 sp, dc in next 8 dc, 2 dc in next corner ch-5 sp, turn—29 dc.

ROWS 2–4: Ch 2 (does not count as a st), dc in each dc across, turn.

Fasten off.

LOG 2

Turn square 90 degrees counterclockwise, so Log 1 is on left side of square.

ROW 1: With RS facing, join CC2 with sl st in right-hand corner ch-5 sp, ch 3

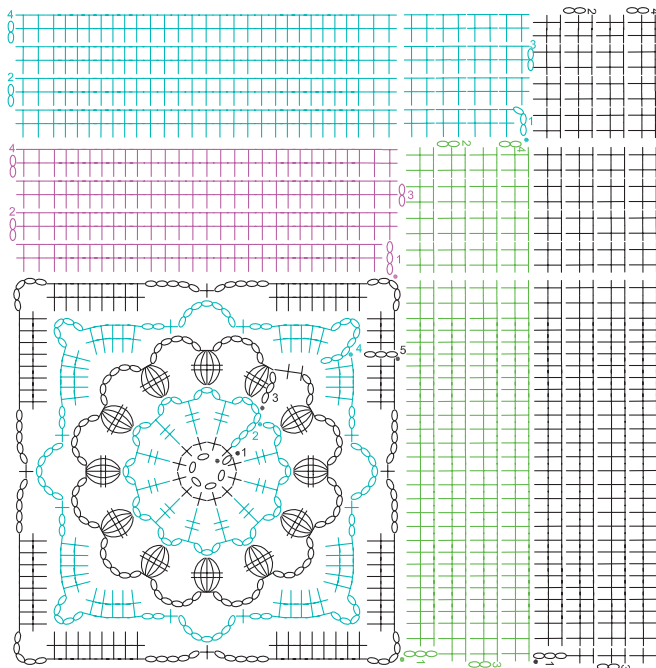

flower motif

(counts as dc), dc in same sp, dc in next 8 dc, 4 dc in ch-5 sp, dc in next sc, 4 dc in next ch-sp, dc in next 8 dc, 2 dc in next corner ch-5 sp, 2 dc around each row-end dc of Log 1, turn—37 dc.

ROWS 2–4: Ch 2 (does not count as a st), dc in first dc and in each dc across, turn.

Fasten off.

LOG 3

Turn square 90 degrees clockwise so Log 2 is on right side of square.

ROW 1: With RS facing, join CC3 with sl st in top right-hand corner (row-end st of Row 4 of Log 2), ch 3 (counts as dc), dc in same row-end st, work 2 dc around each row-end dc of Log 2, then dc in each dc of Log 1, turn—37 dc.

ROWS 2–4: Ch 2 (does not count as a st), dc in first dc and in each dc across, turn.

Fasten off.

LOG 4

Turn square 90 degrees counterclockwise, so Log 3 is on left side of square.

ROW 1: With RS facing, join CC1 with sl st in top right-hand corner (last dc of row 4 of Log 2), ch 3 (counts as dc), dc in each dc of Log 2, 2 dc around each row-end dc of Log 3 turn—45 dc.

ROWS 2–4: Ch 2 (does not count as a st), dc in first dc and in each dc across, turn.

Fasten off.

SQUARE EDGING

RND 1: With RS facing, join CC2 in any corner of square, ch 1, sc evenly around, working 1 sc in each dc, 2 sc in each row-end dc on edges of logs, and 1 sc in each corner st, sl st in first sc of edging to join—184 sts.

RND 2: Ch 1, sc in each sc around, working 3 sc in each corner st—192 sts.



This afghan is simple to crochet, but it's crucial to block it thoroughly.

I pinned out each square according to measurements on my ironing board, wrong side up, and—believe it or not—ironed the square. Be careful if using another yarn than the one specified—synthetics will melt if ironed.

—ANNETTE PETAVY

finishing

BLOCKING AND SEAMING

Block the squares severely to stretch out the flower motif (see Notes). Pin them out to measurements, WS up, and iron lightly but thoroughly (preferably with a steam iron—if you don't have one, spray your square with water first). Let dry completely before removing pins.

Sew together 4 large squares as indicated in Assembly Diagram. Sew these 4 large squares together to form the square-shaped afghan.

BORDER

RND 1: With MC, dc around, working 3 dc in each of the 4 corners, sl st in first dc to join.

RND 2: With CC1, rep Rnd 1.

Fasten off. Weave in loose ends.

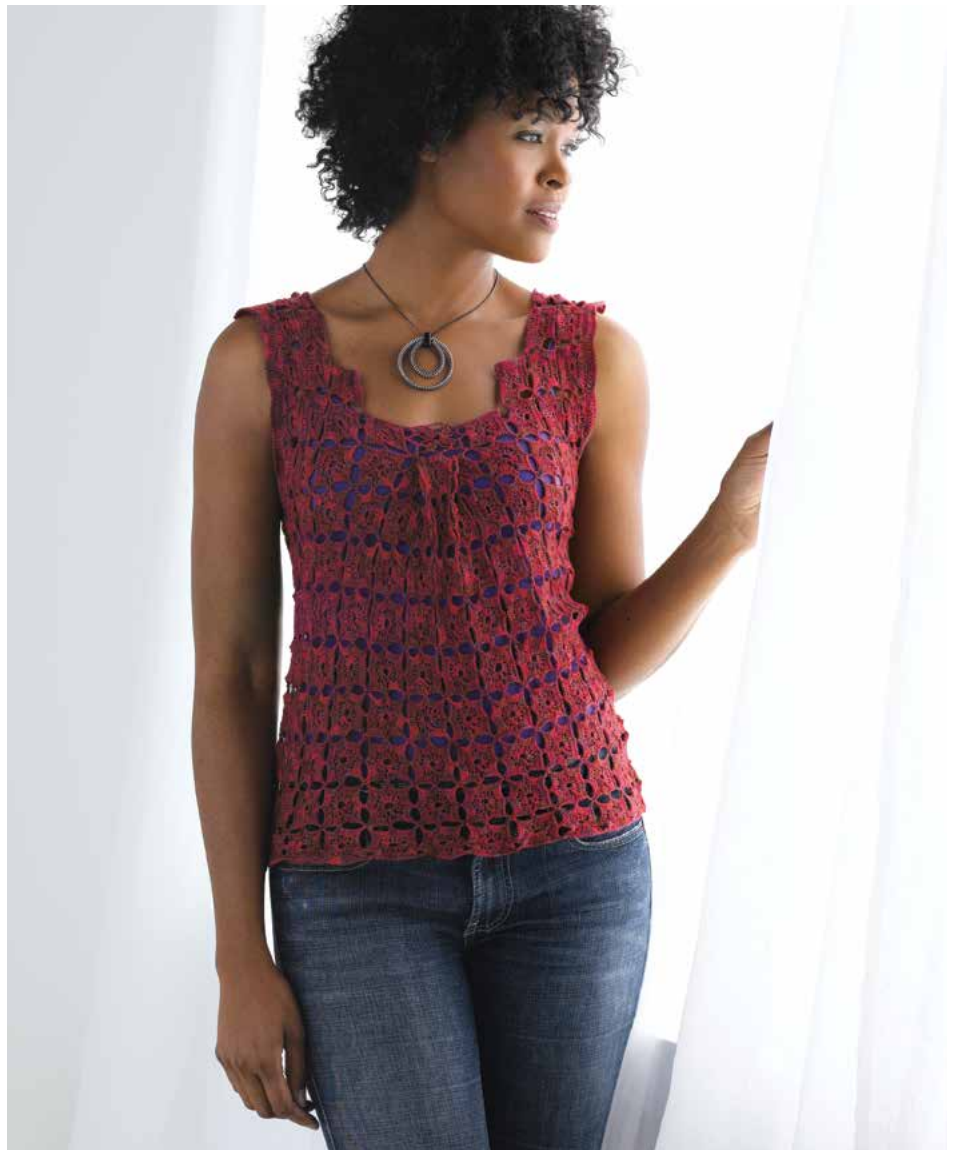

PHOTOS BY JOE HANCOCK

serene BOX PLEAT TOP

BY KRISTIN OMDAHL

This sophisticated top flatters the figure with generous hip ease and clever yet simple shaping at the bust. Folding five motifs into a pretty box pleat at the bust creates a stunning visual effect that is further accentuated by the stepped neckline. A second motif used on the back creates an airy, openwork design.





YARN

Laceweight (#0 Lace); 950 (1,200, 1,525) yd (869 (1,097, 1,394.5) m).

shown: Lorna's Laces, Helen's Lace (50% silk/50% wool; 1,250 yd [1,143 m]/4 oz [113.4 g]); red rover, 1 (1, 2) skeins.

HOOK

C/2 (2.75mm) or size needed to obtain gauge.

NOTIONS

Tapestry needle.

GAUGE

Each motif is 2" (5 cm) square, after blocking.

FINISHED SIZE

Size S (M, L) fits 36 (42, 50)" (91.5 [106.5, 127] cm) bust circumference.

26 (28, 30)" (66 [71, 76] cm) total length. Top shown is a size S.

notes

- There are no seams to sew; the top is completely joined as you go.
- The last motif A (in the top center of the front) is not completed until the box pleat is formed.
- This design features two different motifs, but you could also make this sweater using only one or the other.

special stitches

3-tr cluster (3-tr cl) p. 158.

4-tr cluster (4-tr cl) p.158.

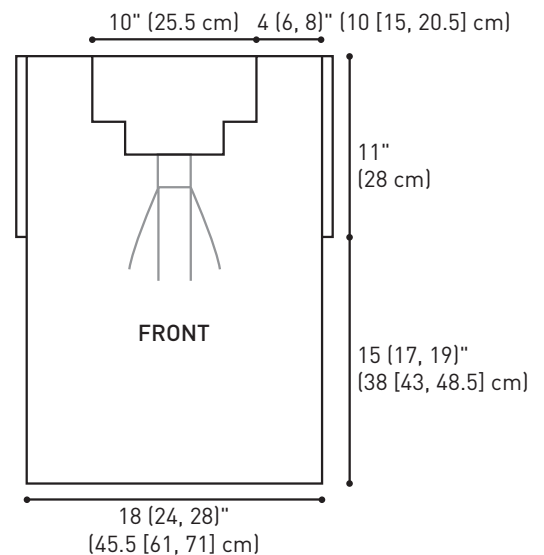

stitch diagram A

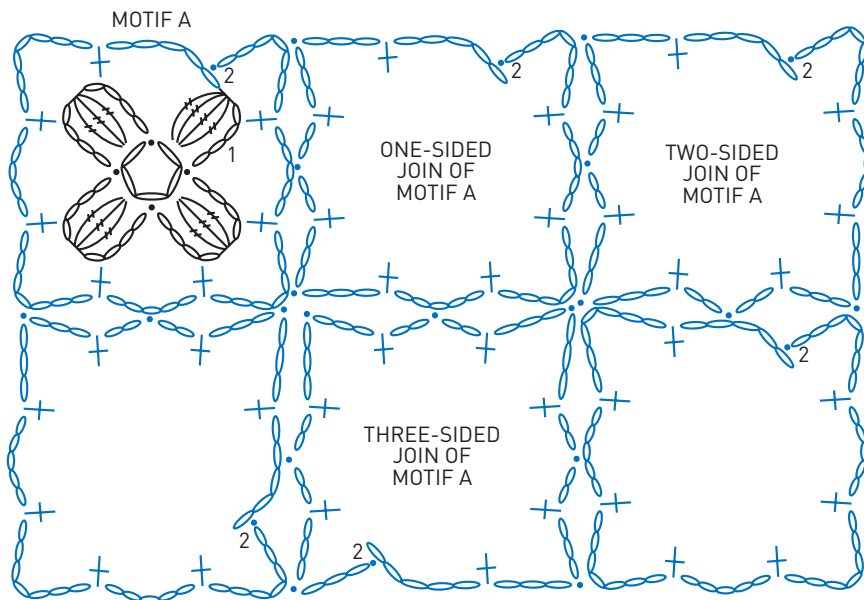

stitch diagram B

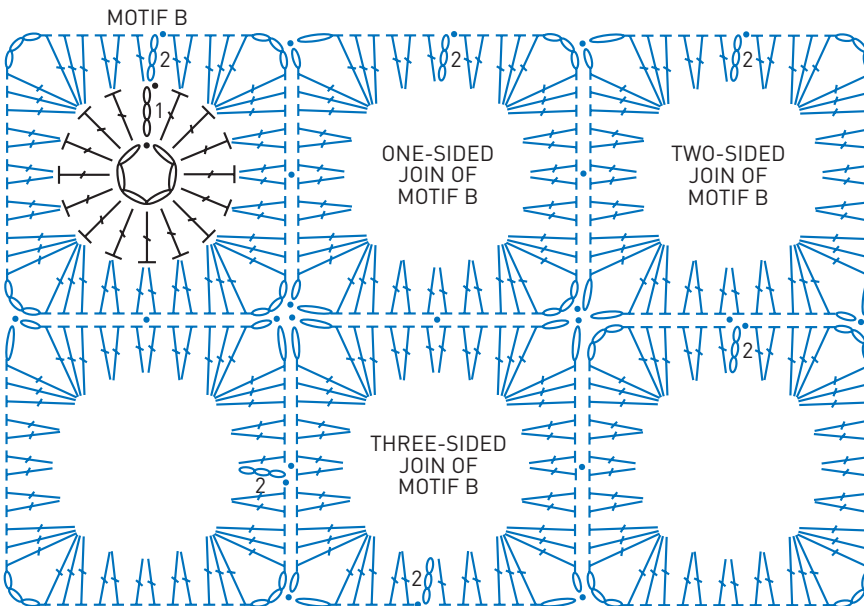

stitch key

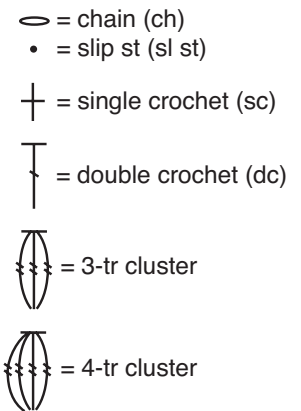

Serene Box-Pleat Top

Motif A

Refer to stitch diagram A at right for assistance.

First Motif: Ch 5, join with sl st to form ring.

RND 1: [Ch 4, 3-tr cl in ring, ch 4, sl st in ring] 3 times, ch 4, 4-tr cl in ring, do not join.

RND 2: Ch 5, sc in next ch-4 sp, ch 7, sc in next ch-4 sp, *ch 5, sc in next ch-4 sp, ch 7, sc in next ch-4 sp, rep from * twice, omitting last sc, join with sl st to first ch at beg of rnd. Fasten off.

One-Sided Join Motif: Rep Rnd 1 of First Motif.

RND 2: Ch 5, sc in next ch-4 sp, ch 3, sl st in corresponding ch-7 lp of adjacent motif, ch 3, sc in next ch-4 sp, ch 2, sl st in next ch-5 sp on adjacent motif, ch 2, sc in next ch-4 sp, ch 3, sl st in next ch-7 sp on adjacent motif, ch 3, sc in next ch-4 sp, *ch 5, sc in next ch-4 sp, ch 7*, sc in next ch-4 sp, rep from * to * once, join with sl st to first ch at beg of rnd. Fasten off.

Two-Sided Join Motif: Rep Rnd 1 of First Motif.

RND 2: Ch 5, sc in next ch-4 sp, ch 3, sl st in corresponding ch-7 lp of ad-

jacent motif, ch 3, sc in next ch-4 sp, *ch 2, sl st in next ch-5 sp on adjacent motif, ch 2, sc in next ch-4 sp, ch 3, sl st in next ch-7 sp on adjacent motif, ch 3, sc in next ch-4 sp, rep from * once, ch 5, sc in next ch-4 sp, ch 7, join with sl st to first ch at beg of rnd. Fasten off.

Three-Sided Join Motif: Rep Rnd 1 of First Motif.

RND 2: Ch 5, sc in next ch-4 sp, ch 3, sl st in corresponding ch-7 lp of adjacent motif, ch 3, sc in next ch-4 sp, *ch 2, sl st in next ch-5 sp on adjacent motif, ch 2, sc in next ch-4 sp, ch 3, sl st in next ch-7 sp on adjacent motif, ch 3, sc in next ch-4 sp, rep from * twice, omitting last sc, join with sl st to first ch at beg of rnd. Fasten off.

Motif B

Refer to stitch diagram B on p. 123 for assistance.

First Motif: Ch 6, join with sl st to form ring.

RND 1: Ch 3 (counts as dc), work 15 dc in ring, join with sl st to top of ch-3 at beg of rnd—16 sts.

RND 2: Ch 3 (counts as dc), dc in first st, 2 dc in next st, [3 dc, ch 3, 3 dc] in next st, *2 dc in each of next 3 sts, [3 dc, ch 3, 3 dc] in next st, rep from * twice, 2 dc in last st, join with sl st to top of ch-3 at beg of rnd. Fasten off.

One-Sided Join Motif: Rep Rnd 1 of First Motif.

RND 2: Ch 3 (counts as dc), dc in first st, 2 dc in next st, [3 dc, ch 1, sl st in corresponding ch-3 sp on adjacent motif, 3 dc] in next st, 2 dc in next st, [dc, sl st in corresponding sp on adjacent motif, dc] in next st, 2 dc in next st, (3 dc, ch 1, sl st in corresponding ch-3 sp on adjacent motif, 3 dc) in next st, *2 dc in each of next 3 sts, (3 dc, ch 3, 3 dc) in next st, rep from * once, 2 dc in last st, join with sl st to top of ch-3 at beg of rnd. Fasten off.

Two-Sided Join Motif: Rep Rnd 1 of First Motif.



RND 2: Ch 3 (counts as dc), dc in first st, 2 dc in next st, (3 dc, ch 1, sl st in corresponding ch-3 sp on adjacent motif, 3 dc) in next st, *2 dc in next st, (dc, sl st in corresponding sp on adjacent motif, dc) in next st, 2 dc in next st, (3 dc, ch 1, sl st in corresponding ch-3 sp on adjacent motif, 3 dc) in next st, rep from * once, 2 dc in each of next 3 sts, (3 dc, ch 3, 3 dc) in next st, 2 dc in last st, join with sl st to top of ch-3 at beg of rnd. Fasten off.

Three-Sided Join Motif: Rep Rnd 1 of First Motif.

RND 2: Ch 3 (counts as dc), dc in first st, 2 dc in next st, (3 dc, ch 1, sl st in corresponding ch-3 sp on adjacent motif, 3 dc) in next st, *2 dc in next st, (dc, sl st in corresponding sp on adjacent motif, dc) in next st, 2 dc in next st, (3 dc, ch 1, sl st in corresponding ch-3 sp on adjacent motif, 3 dc) in

next st, rep from * twice, 2 dc in last st, join with sl st to top of ch-3 at beg of rnd. Fasten off.

Back

Following the back construction diagram, make and join 61 (69, 75) Motif A and 56 (85, 120) Motif B.

Front

Following the front construction diagram, make and join 139 (180, 225) Motif B, joining them to the Back as you go, leaving top 5½ motifs unjoined for armholes (red line on diagram).

Box pleat is worked with the top center 5 motifs of Front. Holding the center motif in front, fold the motifs on either side to the back of the center motif, layering the next motif on either side behind the center motif (see diagram C below). The box pleat will be 5 layers of motifs thick. Using a tapestry needle and long piece of MC yarn, sew through all 5 thicknesses to secure pleat. Once secure, crochet one more Motif A, joining it on 3 sides to top of pleat.

Armhole Opening

Join with sl st to any st in armhole opening, ch 3, dc in each st and ch around, join with sl st to top of ch-3 at beg of rnd.

RND 2: Ch 3, dc in each st around, join with sl st to top of ch-3 at beg of rnd. Fasten off.

Rep for 2nd armhole.

Wet or steam block to finished measurements. Weave in any loose ends with a tapestry needle.

back construction diagram

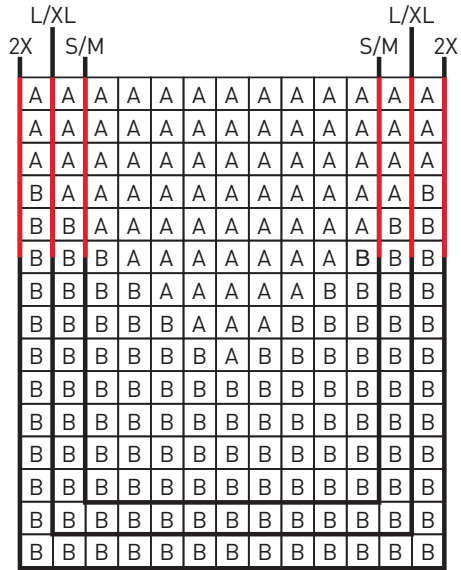

front construction diagram

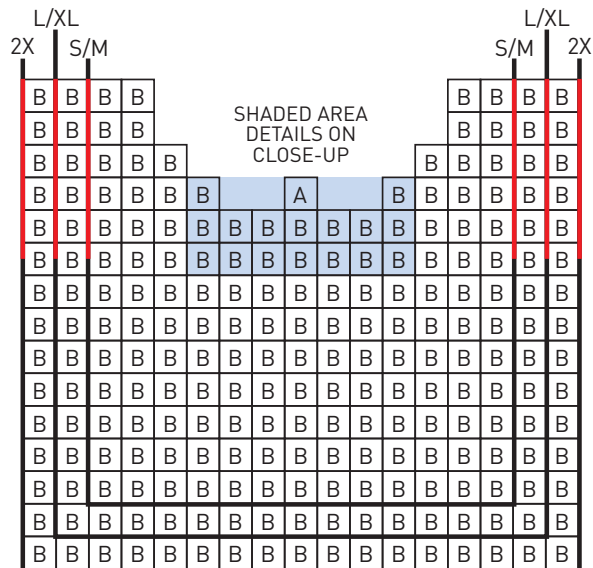
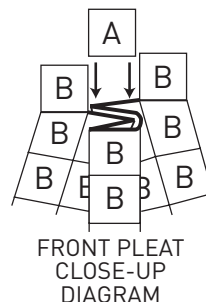

diagram c



KATRINA SHAWL

LISA PFLUG

Lisa Pflug designed a version of this shawl for a friend who lost her home to Hurricane Katrina. Re-envisioned, this frothy swirl evokes watery depths while keeping you warm in the mohair embrace of Kidsilk Haze. Worked in double strands of three shifting colors—trance, jelly, and hurricane—the motifs are joined as you go, creating the central panels first, then adding the outer motifs.

GETTING STARTED

FINISHED SIZE 90" wide and 25" long.

YARN Rowan Kidsilk Haze (70% super kid mohair, 30% silk; 229 yd [210 m]/¾ oz [25 g]; ): #582 trance (medium blue, A), #597 jelly (green, B), #632 hurricane (dark blue, C), 4 skeins each. Yarn distributed by Westminster Fibers.

HOOK Size H/8 (5mm). Adjust hook size if necessary to obtain correct gauge.

NOTIONS Yarn needle.

GAUGE Motif 1 = 3⅜" without ch-6 lps and 5" diagonal including ch-6 lps.

SKILL LEVEL Some concentration required. Easily memorized stitch patterns and minimal shaping might require some focus and counting.

Notes

All motifs are worked using 2 strands of yarn held tog and assembled as you go.

Complete center section of shawl first, beg with non-border motif and working diagonal strips (see chart for order and color). Border motifs are worked last.

Stitch Guide

Motif 1

Ch 5, sl st in first ch to form ring.

Rnd 1: Ch 5 (counts as dc and ch 2), [dc in center of ring, ch 2] 9 times, sl st in 3rd ch of beg ch-5 to join—10 dc.

Rnd 2: Ch 3 (counts as dc), [3 dc in next ch-2 sp, dc in next dc] 9 times, 3 dc in next ch-2 sp, sl st in top of



PHOTOS BY JOE COCA

beg ch-3 to join—40 dc.

Rnd 3: Ch 1, sc in same st, [ch 6, (sk next st, sc in next st, ch 1) 4 times, sk next st, sc in next st] 3 times, ch 6, [sk next st, sc in next st, ch 1] 4 times, sl st in beg sc to join. Fasten off.

Border Motif

Rnds 1–2: Work Rnds 1–2 of Motif 1.

Rnd 3: Work Rnd 3 as for motif 1 to corner that will not be joined to another motif, replace corner ch 6 with ch 1, cont Rnd 3 as for Motif 1.

Motifs 2–117

Note: After first motif is completed, all sub-

sequent motifs are joined as you go. When joining 2 motifs, hold WS tog. When joining a ch-6 lp where 2 lps are already joined, sl st in top of joining sl st of previous join.

Join during Rnd 3 at ch-6 sps and 3rd sc along each side as foll: Work Rnds 1–2 of Motif 1. Work Rnd 3 of Motif 1 to first corner join, ch 3, sl st in corresponding ch-6 lp of adjacent motif (AM), ch 3, *[sk next st, sc in next st, ch 1] 2 times, sk next st, sl st in next sc and corresponding sc on AM, ch 1, sk next st, sc in next st, ch 1, sk next sc, sc in next st, ch 3, sl st in corresponding ch-6 lp of AM, ch 3; rep from * if joining a 2nd side, cont Rnd 3 of Motif 1.

Shawl

With AB, make motif 1 (see Stitch Guide). Make 2nd motif, joining to Motif 1 on Rnd 3 (see Stitch Guide). When strip of AB is complete, work strip of BB, attaching motifs to one another as you go. Cont working motifs as shown in chart (page 70) through final motif of 91 CC. Add border motifs, following color and placement on chart. **Edging:** With WS facing, join 2 strands of A in any sc along edge, [ch 1, sc in each sc and ch-1 sp and 3 sc in each ch-3 sp] around entire piece, sl st in beg sc to join. Fasten off and weave in loose ends. Block to measurements.

LISA PFLUG has been crocheting as a hobbyist for about thirty years and designing for about four years. As a scientist, she writes computer code and finds that writing crochet instructions is essentially the same skill—except in the end she has an afghan or a sweater. She lives in Pass Christian, Mississippi, and shares a house with her husband, two dogs, and, according to her husband, more crochet hooks than anybody needs.

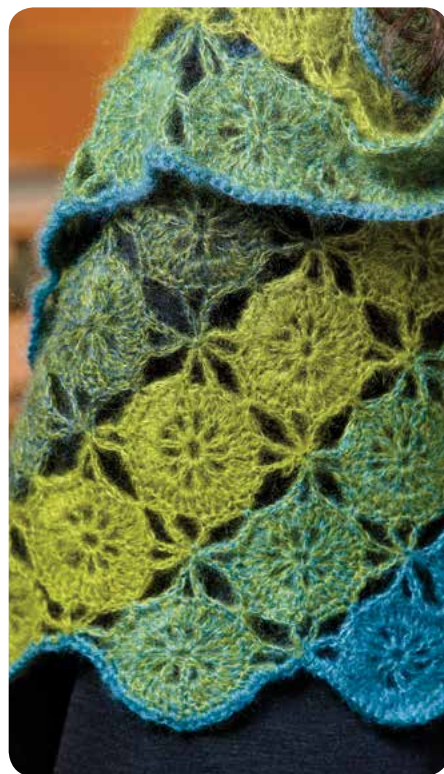
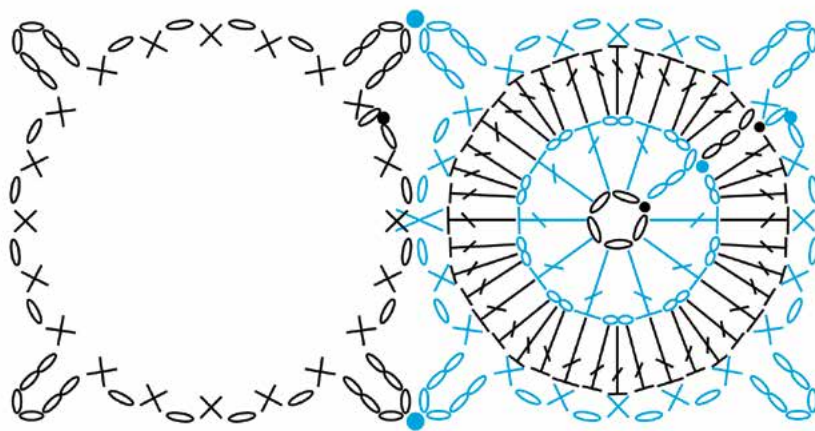
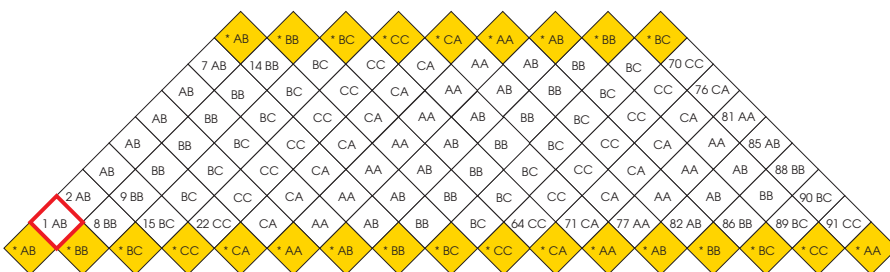
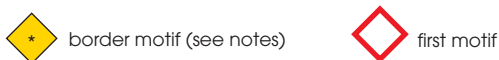

RING AROUND THE POSIE

design by TAMMY HILDEBRAND

LACY, JOIN-AS-YOU-GO MOTIFS WORK UP QUICKLY TO CREATE THIS CASUAL TOP. Style it over a simple cami in a contrasting color to create a trendy, relaxed look or pair it with a matching silk cami for a more sophisticated look.

Finished Size 36 (40½, 45, 48, 54)" bust circumference. Top has relaxed fit with 2–4" ease. Top shown measures 36".

Yarn Valley Yarns Southwick (52% pima cotton, 48% bamboo; 105 yd [96 m]/1¼ oz [50 g]; **W**): #05 margarita, 8 (8, 9, 9, 10) balls. Yarn distributed by WEBS.

Hook Size J/10 (6 mm). Adjust hook size if necessary to obtain the correct gauge.

Notions Yarn needle.

Gauge Motif Rnds 1–3 = 4" square after blocking; 4 V-sts = 4".

Skill Level Intermediate.

Notes

Motifs are joined in strips to create outer and center panels.

Two outer panels begin at back hem, go over shoulder, and end at front hem. Front and back are completed by inserting center panel between outer panels and joining.

When working the panel border, note that different instruction is given for each size to indicate which crochet st to use. Curly brackets are used when different sts are called for.

Stitch Guide

Beginning cluster (beg-cl): Ch 3, [yo, insert hook in indicated sp and pull up a lp, yo and draw through 2 lps on hook] twice, yo and draw through all 3 lps on hook.

Cluster (cl): Yo, insert hook in indicated sp, yo and pull up a lp, yo and draw through 2 lps on hook, [yo, insert hook in same sp, yo and pull up a lp, yo and draw through 2 lps on hook] twice, yo and draw through all 4 lps on hook.

V-st: [Dc, ch 1, dc] in same sp.

Joinings:

Ch-1 join: Sl st in corresponding ch-1 sp on previous panel.



PHOTOS BY PAMELA BETHEL

Ch-3 join: Ch 1, drop lp from hook, insert hook in center ch of corresponding ch-3 on previous motif or panel, pick up dropped lp and pull through, ch 1.

Outer Panel (make 2)

First Motif

Rnd 1: (RS) Ch 3, sl st in first ch to form a ring, work beg-cl (see Stitch Guide) in ring, ch 2, [cl (see Stitch Guide) in ring, ch 2] 7 times, sl st in top of beg-cl to join—8 cl.

Rnd 2: Sl st in next ch-2 sp, ch 1, sc in same sp, ch 3, (cl, ch 3, cl) in next ch-2 sp, ch 3, *sc in next ch-2 sp, ch 3, (cl, ch 3, cl) in next ch-2 sp, ch 3; rep from * to end, sl st in beg sc to join—4 sc, 8 cl.

Rnd 3: Sl st in next ch-3 sp, ch 1, (sc, ch 3, sc) in same sp, *(sc, ch 3, hdc, ch 3, hdc, ch 3, sc) in next ch-3 sp, (sc, ch 3, sc) in each of next 2 ch-3 sps; rep from * 3 times, (sc, ch 3, hdc, ch 3, hdc, ch 3, sc) in next ch-3 sp, (sc, ch 3, sc) in last ch-3 sp, sl st in beg sc to join—24 sc, 8 hdc. Fasten off.

Motifs 2–9:

Rnds 1–2: Rep Rnds 1–2 of first motif.

Note: On Rnd 3 motif is joined to previous motif.

Rnd 3: Sl st in next ch-3 sp, ch 1, (sc, ch 3, sc) in same sp, (sc, ch 3, hdc, ch-3 join [see Stitch Guide], hdc, ch-3 join, sc) in next ch-3 sp, (sc, ch-3 join, sc) in next 2 ch-3 sps, (sc, ch-3 join, hdc, ch-3 join, hdc, ch 3, sc) in next ch-3 sp, *(sc, ch 3, sc) in next 2 ch-3 sps, (sc, ch 3, hdc, ch 3, hdc, ch 3, sc) in next ch-3 sp; rep from * once, (sc, ch 3, sc) in last ch-3 sp, sl st in beg sc to join. Fasten off.

Center Panels (make 2 [2, 2, 4, 4] panels)

Motifs 1–4: Rep instructions for outer panel, creating 4-motif-long strips.

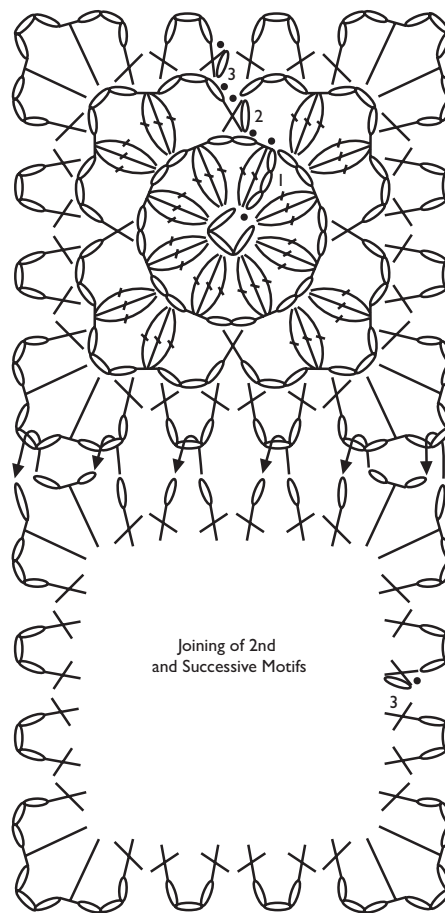
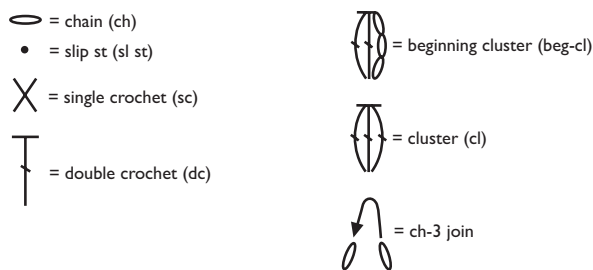
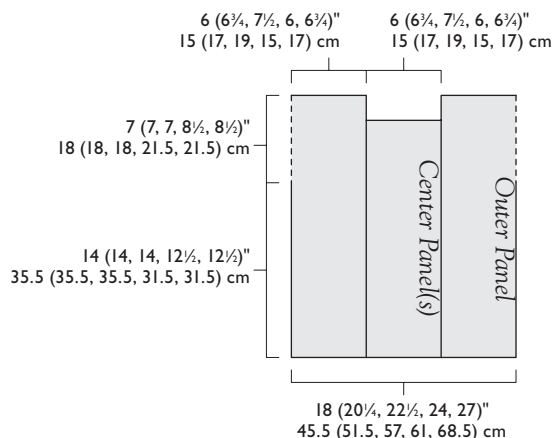

Panel Border

Rnd 1: With RS facing, join yarn with sc in first ch-3 corner sp of long edge of any panel, 2 sc in same sp, 3 sc {hdc, dc, sc, hdc} (see Notes) in each ch-3 sp to motif joining, *3 dc in next motif joining, 3 sc {hdc, dc, sc, hdc} in each ch-3 sp to next motif joining; rep from * around panel, sl st in beg sc to join to outer panel—252 sc {252 hdc, 252 dc, 252 sc, 252 hdc}, 48 dc; center panel: 132 sc {132 hdc, 132 dc, 132 sc, 132 hdc}, 18 dc.

Rnd 2: Sl st to center st of first 3-st corner group, ch 6 (counts as dc, ch 3), dc in same st, [V-st (see Stitch Guide) in sp

before next 3-st group] to next corner, *(dc, ch 3, dc) in center st of next 3-st corner group, (V-st in sp before next 3-st group; rep from * around, sl st in 3rd ch of beg ch-6 to join to outer panel—100 V-sts; center panel: 50 V-sts.

Outer panels only:

Rnd 3: Sl st in next ch-3 sp, ch 1, (sc, ch 3, sc) in same sp, (sc, ch 1, sc) in each V-st to next corner, *(sc, ch 3, sc) in next ch-3 sp, (sc, ch 1, sc) in each V-st to next corner; rep from * to end, sl st in beg sc to join—200 sc, 100 ch-1 sps. Fasten off.

Center panels only:

Sizes 36 (40½, 45)" only: First center panel:

Rnd 3: Sl st in next ch-3 sp, join to first outer panel as foll: (sc, ch-3 join [see Stitch Guide], sc) in same sp, (sc, ch-1 join [see Stitch Guide], sc) in next 20 ch-1 sps, (sc, ch-3 join, sc) next ch-3 sp of center panel to next ch-1 sp of outer panel, (sc, ch 1, sc) in next 5 ch-1 sps, join center panel to ch-1 sp of 21st V-st from edge of 2nd outer panel as foll: (sc, ch-3 join, sc) next ch-3 sp of center panel to ch-1 sp of outer panel, (sc, ch-1 join, sc) in next 20 ch-1 sps, (sc, ch-3 join, sc) in last ch-3 sp, (sc, ch 1, sc) in next 5 ch-1 sps, sl st in beg sc to join—108 sc, 50 ch-1 sps. Fasten off.

Second center panel:

Rnd 3: Sl st in next ch-3 sp, join to first outer panel as foll: sk next 3 V-sts from first center panel for neck opening, (sc, ch-3 join, sc) in same sp on center panel to next ch-1 sp on outer panel, (sc, ch-1 join, sc) in next 20 ch-1 sps, (sc, ch-3 join, sc) in next ch-3 sp, (sc, ch 1, sc) in next 5 ch-1 sps, join center panel to 2nd outer panel as foll: (sc, ch-3 join, sc) in next ch-3 sp, (sc, ch-1 join, sc) to last ch-3 sp of center panel, (sc, ch-3 join, sc) in last ch-3 sp to next ch-1 sp of outer panel, (sc, ch 1, sc) in next 5 ch-1 sps, sl st in beg sc to join. Fasten off.

Sizes 48 (54)" only: First center panel:

Rnd 3: Sl st in next ch-3 sp, join to first outer panel as foll: (sc, ch-3 join [see Stitch Guide], sc) in same sp, (sc, ch-1 join [see Stitch Guide], sc) in next 20 ch-1 sps, (sc, ch-3 join, sc) in next ch-3 sp of center panel to next ch-1 sp of outer panel, (sc, ch 1, sc) in next 5 ch-1 sps, (sc, ch 3, sc) in next ch-3 sp on opposite side of panel, (sc, ch 1, sc) to last ch-3 sp, (sc, ch 3, sc) in last ch-3 sp, (sc, ch 1, sc) in next 5 ch-1 sps, sl st in beg sc to join—96 sc, 48 ch-1 sps. Fasten off.

Second center panel:

Rnd 3: Sl st in next ch-3 sp, join to first center panel as foll: (sc, ch-3 join, sc) in same sp, (sc, ch-1 join, sc) in next 20 ch-1 sps, (sc, ch-3 join, sc) in next ch-3 sp, (sc, ch 1, sc) in next 5 ch-1 sps, join center panel to ch-1 sp of 21 V-sts from edge of 2nd outer panel as foll: (sc, ch-3 join, sc) in next ch-3 sp to ch-1 sp of outer panel, (sc, ch-1 join, sc) to last ch-3 sp, (sc, ch-3 join, sc) in last ch-3 sp, (sc, ch 1, sc) in next 5 ch-1 sps, sl st in beg sc to join—108 sc, 50 ch-1 sps. Fasten off.

Third center panel:

Rnd 3: Sl st in next ch-3 sp, join to opposite end of first outer

panel as foll: sk next 3 V-sts from first center panel for neck opening, (sc, ch-3 join, sc) in same sp on center panel to next ch-1 sp on outer panel, (sc, ch-1 join, sc) in next 20 ch-1 sps, (sc, ch-3 join, sc) in next ch-3 sp, (sc, ch 1, sc) in next 5 ch-1 sps, (sc, ch 3, sc) in next ch-3 sp on opposite side of center panel, (sc, ch 1, sc) to last ch-3 sp, (sc, ch 3 join, sc) in last ch-3 sp, (sc, ch 1, sc) in next 5 ch-1 sps, sl st in beg sc to join. Fasten off.

Fourth center panel:

Rnd 3: Joining to 3rd center panel, rep as for 2nd center panel.

Side Selvedge (all sizes)

First side:

Row 1: With RS facing, join yarn with sc in ch-3 sp at bottom right of first strip, 2 sc in same sp, ch 1, *3 sc in next ch-1 sp, ch 1; rep from * to next ch-3 sp, 3 sc in ch-3 sp—141 sc, 46 ch-1 sps. Fasten off.

Rep for 2nd side.

Assembly

Holding front and back with WS tog, using yarn needle, and beg at bottom edge, whipstitch first 48 (48, 48, 42, 42) sts and 16 (16, 16, 14, 14) ch-1 sps tog through blo (see page 20); leave rem sts open for armhole. Rep for 2nd side.

Sleeves

Rnd 1: With RS facing, join yarn with sc in center of seam at armhole opening, sc in next ch-1 sp, [sc in center st of next 3-st group, sc in next ch-1 sp] 2 (2, 2, 3, 3) times, [V-st in center st of next 3-st group] 9 times, sc in next ch-1 sp, [sc in center st of next 3-st group, sc in next ch-1 sp] 2 (2, 2, 3, 3) times, sl st in beg



sc to join—11 (11, 11, 15, 15) sc, 9 V-sts.

Rnd 2: Sl st in each sc to first V-st, ch 1, 3 hdc in next ch-1 sp, [ch 1, sl st in sp before next V-st, ch 1, 3 hdc in next ch-1 sp] 8 times, ch 1, sl st in each sc to end. Fasten off.

Neck Shaping

Size 36 (40½, 45)" only:

Rnd 1: Working around neck opening, join yarn in center of panel border at top right of center panel, (ch 2, 2 hdc) in same sp, *[sc in sp before next V-st, 3 hdc in next ch-1 sp] 5 times, sc in sp after last V-st, 3 hdc in center of next panel joining, [sc in sp before next V-st, 3 hdc in next ch-1 sp] 3 times, sc in sp after last V-st, 3 hdc in center of next panel joining; rep from * omitting last 3 hdc, sl st in beg ch to join—20 sc, 60 hdc.

Size 48 (54)" only:

Rnd 1: Working around neck opening, join yarn in center of panel border at top right of center panel, (ch 2, 2 hdc) in same sp, *[sc in sp before next V-st, 3 hdc in next ch-1 sp] 5 times, sc in sp after last V-st, 3 hdc in center of next panel joining] twice, [sc in sp before next V-st, 3 hdc in next ch-1 sp] 3 times, sc in sp after last V-st, 3 hdc in center of next panel joining; rep from * omitting last 3 hdc, sl st in beg ch to join—32 sc, 96 hdc.

Bottom Edging (all sizes)

Rnd 1: Join yarn with sl st in center of either side seam, ch 4 (counts as tr), 4 tr in same sp, ch 1, *[sc in sp before next V-st, ch 1, 3 hdc in next ch-1 sp, ch 1] 5 times, sc in sp after last V-st, ch 1, 5 tr in center of panel joining, ch 1] 2 (2, 2, 3, 3) times, [sc in sp before next V-st, ch 1, 3 hdc in next ch-1 sp, ch 1] 5 times, sc in sp after last V-st, ch 1, 5 tr in center of next side seam, ch 1; rep from * omitting last 5 tr and ch 1, sl st in top of beg ch to join—36 (36, 36, 48, 48) sc, 24 (24, 24, 32, 32) hdc, 30 (30, 30, 40, 40) tr.

Fasten off. Handwash and lay flat to dry, opening up the lace pattern and blocking to finished measurements.



TAMMY HILDEBRAND learned how to crochet from her second-grade teacher, Gail Crooks. Tammy contacted her teacher when her first design was published many years ago. They have remained in contact ever since, and Gail has worked from Tammy's patterns!



PHOTO BY JOE COCCA

CARMEN'S JAZZ

design by SUE B. BALCOM



FINISHED SIZE 101" long and about 9½" wide.

YARN Stitch Nation by Debbie Stoller Alpaca Love (80% wool, 20% alpaca; 132 yd [121 m]/3 oz [85 g]; **(4)**): #3620 fern (green; A), #3650 lotus (pink; B), #3810 lake (light teal; C), #3520 peacock feather (dark teal; D), #3580 dusk (purple; E), 1 skein each; #3920 ruby (red; F), 2 skeins. Yarn distributed by Coats & Clark.

HOOK Size H/8 [5 mm]. Adjust hook size if necessary to obtain correct gauge.

NOTIONS Yarn needle.

GAUGE 12 sts and 6 rows = 4" in dc. Each square = 8¼" from tip of large sh to tip of opposite large sh.

SKILL LEVEL Fair amount of focus required. Involved stitch patterns, shaping, or assembly require fairly constant concentration.

Notes

Weave in ends as you go.

Scarf is constructed with 12 full and 20 quarter motifs, plus border. If you wish to use only 10 large motifs, it would measure 84½" long by 9½" wide.

Use the largest leftover skein to connect the quarter motifs to the full motifs, so you don't run out of yarn, or purchase an extra skein of your favorite color.

All sts are crocheted through both lps.

Stitch Guide

Large shell: (Sc, hdc, 3 dc, 2 tr) in indicated ch-sp, (2 tr, 3 dc, hdc, sc) in next ch-sp.

Small shell: (Sc, hdc, 4 dc, hdc, sc) in indicated ch sp.

Large motif (make 12)

Using the color chart (see page 16), beg at the top of the chart, and working down, work motifs simultaneously rnd by rnd connecting them bet the 4 tr on the last rnd.

Rnd 1: Work adjustable ring (see page 20), ch 2 (counts as dc throughout), 11 dc in ring, sl st in top of beg ch-2 to join—12 dc. Fasten off. Pull tail to tighten ring.

Rnd 2: Join new color in any dc, ch 2, dc in same st, ch 1, [2 dc in next dc, ch 1] 11 times, sl st in top of beg ch-2 to join—24 dc.

Rnd 3: Ch 1, sc in first st, sc in next st, ch 1, *sc in next 2 dc, ch 1; rep from * around, sl st in beg sc to join—12 ch-1 sps. Fasten off.

Rnd 4: Join new color with sc in any ch-1 sp, ch 4, *sc in next ch-1 sp, ch 4; rep from * around, sl st in beg sc to join—12 ch-4 sps.

Rnd 5: Sl st in first ch-4 sp, sc in same ch-4 sp, *ch 5, sc in next ch-4 sp; rep from * around, ch 5, sl st in beg sc to join—12 ch-5 sps. Fasten off.

Rnd 6: Join new color with sc in any ch-5 sp, ch 6, sc in next ch-5 sp, ch 6, dc in next ch-5 sp, ch 6, *sc in next ch-5 sp, ch 6] 2 times, dc in next ch-5 sp, ch 6; rep from * around, sl st in beg sc to join—12 ch-6 sps.

Rnd 7: (First motif) *Small sh (see Stitch Guide) in first ch-6 sp, large sh (see Stitch Guide); rep from * around, sl st in beg sc to join. Fasten off.

Rnd 7: (Subsequent motifs) Work as for Rnd 7 (first motif), joining motifs bet last set of tr sts as foll: 2 tr, remove hook from lp, pull the lp bet the center 2 tr of the adjacent motif, cont patt with next 2 tr.

Quarter motifs (make 22 in any color combo)

Ch 4, sl st in first ch to form ring.

Row 1: (RS) Ch 3 (counts as dc and ch 1), (dc, ch 1) 4 times in ring, dc—6 dc. Fasten off.

Row 2: With WS facing, join new color with sc in first ch-1 sp, *ch 3, sc in next ch-1 sp; rep from * to end, turn—4 ch-3 sps.

Row 3: Ch 6 (counts as dc and ch 3), 3 dc in first ch-3 sp, ch 3, 3 dc in next ch-3 sp, ch 6, 3 dc in next ch-3 sp, ch 3, 3 dc in last ch-3 sp, ch 6, sl st to beg sc of Row 2. Fasten off.

Connecting the quarter motifs

Lay scarf on table with RS facing, arrange quarter motifs bet large motifs. Beg at first large motif on your right with the side farthest away from you.

Key

- = sl st (slip stitch)
- = ch (chain)
- × = sc (single crochet)
- ┐ = hdc (half double crochet)
- ┆ = dc (double crochet)
- ┆ = tr (treble)
- = beg ring

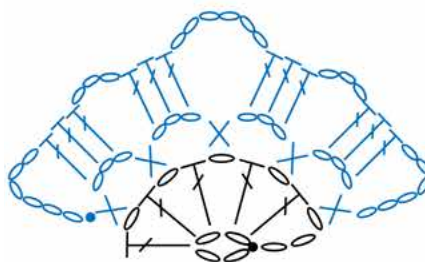

Large Motif

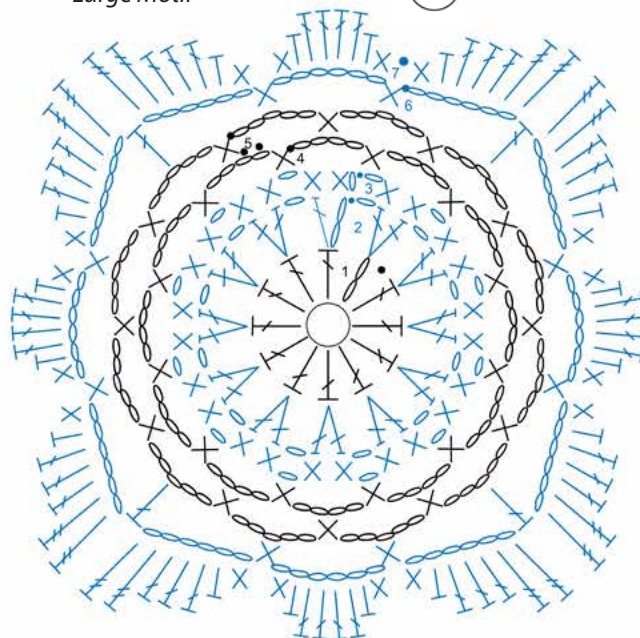

Color Chart:

Motif	Row 1	Rows 2-3	Rows 4-5	Rows 6-7
1	B	D	F	C
2	E	B	D	E
3	C	D	E	A
4	F	C	B	D
5	F	A	D	B
6	A	B	C	F
7	A	E	F	D
8	E	C	B	A
9	C	F	C	B
10	B	E	A	F
11	D	A	E	C
12	D	F	A	E

Join A (or any color chosen) with sc to first large motif bet first 4 tr to the right of where the first and 2nd large motifs join.

Work back and forth from quarter motif (QM) to large motif (LM): *Ch 6, sc in first ch-6 sp of QM; ch 3, sc in

next hdc of large sh on LM; ch 3, sc in next ch-3 sp of QM; ch 3, sc bet the 4 dc of small sh on LM; ch 3, sc in ch-6 sp of QM; ch 3, sc in dc of large sh on LM; ch 3, sc in dc of large sh on next LM; ch 3, sc in same ch-6 sp on QM as before; ch 3, sc bet 4 dc of small

sh on LM; ch 3, sc in ch-3 sp on QM; ch 3, sc in hdc of large sh on LM; ch 3, sc in ch-6 sp on QM; ch 6, sc bet 4 tr of large sh on LM; rep from * 10 times. Cont around end of last motif as foll: [Ch 6, sc in hdc, ch 6, sc bet 4 dc of small sh, ch 6, sc in hdc, ch 6, sc bet 4 tr of large sh] 2 times. Rep from * along the other edge of scarf, to beg sc, sl st in beg sc to join, fasten off and weave in ends.

Finishing

Join F bet Rows 1 and 2 of first QM, *5 dc in beg ch-4 sp of QM, sc bet Rows 1 and 2 of QM, [5 dc in next sc, sc in next ch-6 sp] 2 times, 5 dc in next sc, sc in sc bet Rows 1 and 2 of next QM; rep from * around, sl st in beg sc to join. Fasten off and weave in ends. Block to measurements.

SUE B. BALCOM is a fiber addict. She still has the last doily her grandmother was crocheting as well as her yarn basket. Her house has no fewer than three unfinished projects in various rooms, plus the ones floating around in her brain.



WEAVING IN LOOSE ENDS

After investing countless hours with hook and yarn in hand, fussily perfecting every stitch of a crochet project you've been envisioning, you want to finish it with as much finesse as invested in each stitch. After the seaming is done, you will have some, possibly many, dangling ends. Work those into the fabric professionally following these easy steps.

The first step actually comes when you begin the project and every time you start a new color or ball of yarn: Leave at least 6 inches of yarn for every yarn end. A frequent rookie error is leaving stubby little tails. This bit of frugality never pays off, as little ends have a way of wiggling out later.

Fastening off: On the last stitch, do not work a turning chain. Cut the yarn, leaving at least 6 inches. Draw the end through the last loop on the hook and pull snugly to tighten.

Weaving in loose ends: Thread the yarn tail on a blunt-ended tapestry needle. For thread or laceweight yarn, use a smaller needle with a blunt end. A blunt ended needle helps prevent splitting of the stitches when weaving in loose ends. For bulky yarn, split fastened-off ends in half and weave in both new ends separately to prevent bulk caused by the woven ends.

For all weights of yarn, work ends on the wrong side of the project. Where possible, weave ends into seam allowances. For solid fabric, there are other options for locations to weave in your loose ends: Weave the ends in straight down the work or work the yarn in a zigzag, until the yarn is nearly used up. Work the last few stitches in the opposite direction, making sure the ends are securely fastened in and cannot be pulled back out. If you do find you have left your ends a bit short, try weaving your needle through the fabric before threading the needle. When the needle is woven through the fabric, with the needle's eye closest to the tail, thread the yarn and pull the needle through. To ensure that the woven-in ends are not visible from the right side, weave the needle through the crochet fabric on the wrong side and then turn the fabric over and make sure you can't see the needle from the right side. For lace fabric, work down through the solid stitch area, without carrying the yarn across open lace areas.

When the end is woven in, trim the yarn close to the fabric. Repeat these instructions for all of your loose ends.



draw end through last loop on hook



where possible, weave ends into seam allowances



for solid fabric, work the ends into the yarns on the wrong side

Abbreviations

beg	begin(s); beginning
bet	between
blo	back loop only
CC	contrasting color
ch	chain
cm	centimeter(s)
cont	continue(s); continuing
dc	double crochet
dtr	double treble crochet
dec(s)('d)	decrease(s); decreasing; decreased
est	established
fdc	foundation double crochet
flo	front loop only
foll	follows; following
fsc	foundation single crochet
g	gram(s)
hdc	half double crochet
inc(s)('d)	increase(s); increasing; increased
k	knit
lp(s)	loop(s)
MC	main color
m	marker
mm	millimeter(s)
patt(s)	pattern(s)
pm	place marker
p	purl
rem	remain(s); remaining
rep	repeat; repeating
rev sc	reverse single crochet
rnd(s)	round(s)
RS	right side
sc	single crochet
sk	skip
sl	slip
sl st	slip(ped) stitch
sp(s)	space(es)
st(s)	stitch(es)
tch	turning chain
tog	together
tr	treble crochet
WS	wrong side
yd	yard
yo	yarn over hook
*	repeat starting point
()	alternate measurements and/or instructions
[]	work bracketed instructions a specified number of times

ADJUSTABLE RING

Place slipknot on hook, leaving a 4" tail. Wrap tail around fingers to form ring. Work stitches of first round into ring. At end of first round, pull tail to tighten ring.