

EXPLORING KNITTING AND
CROCHET TECHNIQUES:
5 FREE
*Crochet and
Knitting Patterns*



crochetme
linking the crochet community

Exploring Knitting and Crochet Techniques



Exploring Knitting and Crochet Techniques:

5 FREE Crochet and Knitting Patterns

I STARTED CROCHETING AS A TEENAGER. At the same time, I tried my hands at knitting, but two or four needles were too confusing for me. Years later I again picked up a set of knitting needles. I had fallen in love with several projects that beautifully paired the solid textured stitches of knitting with the elegance of crochet lace.

This love of patterns that marry knitting and crochet is what led *Knitting Daily* Editor Kathleen Cubley and me to create this free eBook. As Kathleen says, “Knitting loves crochet. . . . Knitting and crochet are sisters, really, who share the same history and tradition in the world of needle work.” We hope you will enjoy the beauty of both crafts in these exquisite patterns.

The Lacy Cables Scarf by Annette Petavy pairs an elegant knitted cable with an openwork crochet edging. This simple knitting and crochet pattern is a great introduction to knitting cables, and the sophisticated edging is the perfect finishing touch.

A simple stockinette hat is the perfect background for a crochet motif band in the **Snow Queen Hat** by Anastasia Popova. If you are a new crocheter or knitter, this is the perfect pattern to try your skills on. Detailed stitch diagrams help illustrate the delicate crochet motifs.

The Snowflake Sweater by Mari Lynn Patrick uses clever crochet patterning to create beautiful motifs for the front and back of this crochet/knit sweater. Knitted panels are worked around the motifs to create the sweater and inventive crochet seaming joins the pieces to create a remarkable sweater.

The Melange Turtleneck by Katie Himmelberg is a beautiful melding of knit and crochet techniques. A stockinette knit creates a solid body and shell stitch crochet sleeves highlight the ability of crochet to create gorgeous lace. Try this great knit/crochet sweater in a single color or two for an instant favorite.

The BFF Finger Puppets by Marcy Smith bring knit and crochet together in perfect harmony. One doll is knitted and the other is crocheted. Both are simple to create. The features are embroidered. Create an entire village of fiber loving friends for a little girl in your life.

Expand your fiber skills with one of the innovative knitting and crochet patterns in *Exploring Knitting and Crochet Techniques: 5 Free Crochet and Knitting Patterns*. We'd love to see your work. Share photographs of your finished project in the *Crochet Me* Member Gallery.

Best wishes,

Toni Rexroat

Editor, *CrochetMe.com*

1	Lacy Cables Scarf	Annette Petavy	PAGE 4
2	The Snow Queen Hat	Anastasia Popova	PAGE 6
3	Snowflake Sweater	Mari Lynn Patrick	PAGE 8
4	Mélange Turtleneck	Katie Himmelberg	PAGE 12
5	BFF Finger Puppets	Marcy Smith	PAGE 16
	Crochet Basics		PAGE 21
	Glossary		PAGE 22

EXPLORING KNITTING AND CROCHET TECHNIQUES: 5 FREE CROCHET AND KNITTING PATTERNS

A CrochetMe eBook edited by Toni Rexroat, Kathleen Cubley

EDITORIAL STAFF

EDITOR, CROCHETME Toni Rexroat

CREATIVE SERVICES

PRODUCTION DESIGNER Nichole Mulder

PHOTOGRAPHY As Credited

ILLUSTRATION Gayle Ford

Projects and information are for inspiration and personal use only. *Interweave Knits* and *Crochet Me* do not recommend, approve, or endorse any of the advertisers, products, services, or views advertised in this publication. Nor does *Knits* or *Crochet Me* evaluate the advertisers' claims in any way. You should, therefore, use your own judgment in evaluating the advertisers, products, services, and views advertised in *Knits* or *Crochet Me*.



Lacy Cables Scarf

by ANNETTE PETAVY

Originally published in
Interweave Crochet Fall 2010

FINISHED SIZE About 7½" wide and 69" long.

YARN The Fibre Company Road to China Light (65% baby alpaca, 10% cashmere, 10% camel, 15% silk; 159 yd [145 m]/1¼ oz [50 g]; **(B)**: #512 carnelian, 3 skeins. Yarn distributed by Kelbourne Woolens.

HOOK Size E/4 (3.5 mm). Adjust hook size if necessary to obtain correct gauge.

NEEDLES Size 7 (4.5 mm). Adjust needle size if necessary to obtain correct gauge.

NOTIONS Cable needle (cn); stitch markers (m) or waste yarn.

GAUGE 28 sts and 26 rows = 4" in cable patt after blocking; 18 sts and 16 rows = 4" in dc offset mesh.

NOTES

- Center of scarf is knit as a long strip with a reversible cable (worked in 1×1 rib), bordered on each side by garter st.
- Crochet borders are worked in offset mesh patt.

Stitch Guide

6/6 LC: Sl next 6 sts to cable needle (cn), hold in front, [k1, p1] 3 times, [k1, p1] 3 times from cn.

EDGE STS: Sl first st knitwise and purl last st of every row.

CABLE PATT (PANEL OF 12 STS + 16)

Note: Because cable is reversible, there is no RS or WS for patt. **SET-UP**

ROW: K8, [k1, p1] 6 times, k7, p1.

Row 1: Sl 1 (Edge st; see above), k7, [k1, p1] 6 times, k7, p1 (Edge st).

Rows 2–9: Rep Row 1.

Row 10: Sl 1, k7, 6/6 LC (see above), k7, p1.

Rep Rows 1–10 for patt.

Scarf

CENTER CABLE PANEL:

With needles, and using cable method (see Glossary), CO 28 sts. Work cable patt set-up row. Work 10-row rep of cable patt 38 times, then Rows 1–9—390 rows total. BO loosely in patt.

LONG-EDGE BORDER:

Row 1: With hook, join yarn with dc in first edge st at corner of 1 long edge, *ch 1, sk next st, dc in next st, ch 1, dc in next st; rep from * to last 2 sts, ch 1, sk next st, dc in last st, turn—129 ch-1 sps, 130 dc.

Row 2: Ch 2 (does not count as st throughout), dc in first dc, dc in first ch-1 sp, *ch 1, dc in next ch-1 sp; rep from * through last ch-1 sp, dc in last dc, turn—128 ch-1 sps, 131 dc.

Row 3: Ch 2, dc in first dc, ch 1, sk next dc, dc in next ch-1 sp, *ch 1, dc in next ch-1 sp; rep from * through last ch-1 sp, ch 1, sk next dc, dc in last dc, turn—129 ch-1 sps, 130 dc.

Rows 4–5: Rep Rows 2–3.

Row 6: Rep Row 2. Fasten off.

Rep on opposite long side.

SHORT-END BORDER:

Row 1: Join yarn with sc in top of dc at corner of short end of scarf, working across side border, [ch 3, sc in next dc] 5 times, ch 3, sc in first st of cable panel, [ch 3, sc] 11 times evenly spaced across cable panel, cont across crocheted border row-ends, [ch 3, sc in next dc] 6 times, turn—23 ch-3 sps, 24 sc.

Row 2: Ch 2 (does not count as st throughout), dc in first sc, ch 1, sc in first ch-3 sp, *ch 3, sc in next ch-3 sp; rep from * through last ch-3 sp, ch 1, dc in last sc, turn.

Row 3: Ch 1 (does not count as st throughout), sc in first dc, *ch 3, sc in next ch-3 sp; rep from * through last ch-3 sp, ch 3, sc in last dc, turn.

Rows 4–5: Rep Rows 2–3.

Row 6: Ch 2, dc in first sc, ch 2, sc in

first ch-3 sp, *ch 5, sc in next ch-3 sp; rep from * through last ch-3 sp, ch 2, dc in last sc, turn.

Row 7: Ch 1, sc in first dc, *ch 5, sc in next ch-5 sp; rep from * through last ch-5 sp, ch 5, sc in last dc, turn.

Row 8: Ch 2, dc in first sc, ch 2, sc in first ch-5 sp, *ch 5, sc in next ch-5 sp; rep from * through last ch-5 sp, ch 2, dc in last sc, turn.

Rows 9–12: Rep Rows 7–8 two times.

Row 13: Rep Row 7. Fasten off.

Rep short-end border on opposite end of scarf. Weave in loose ends. Block, taking care to pin out the end borders in a fan shape.

ANNETTE PETAVY'S obsession with crochet and love for knitting started when she was a little girl living in Sweden. Her move to France and exposure to French fashion flair have only made things worse. You can follow her fiber adventures at www.annettepetavy.com.

Cable Panel

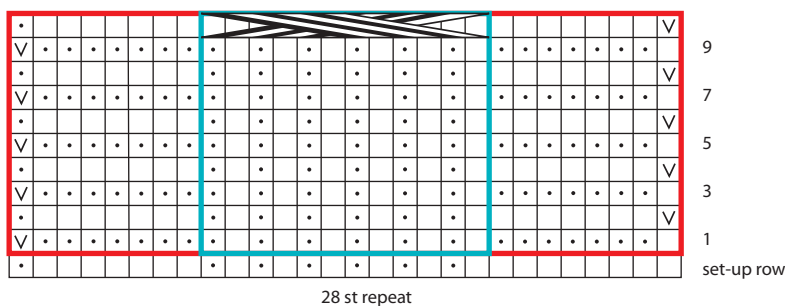
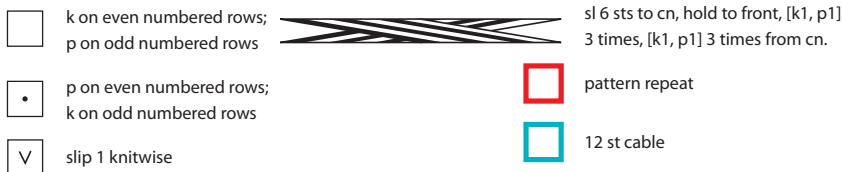



Snow Queen Hat

by **ANASTASIA POPOVA**
Originally published in
Interweave Crochet Fall 2010

FINISHED SIZE 14¼ (16, 17½, 19, 21)" circumference, to fit infant (toddler, child, teen, adult). Hat shown measures 21".

YARN Elann.com Incense (50% wool, 25% silk, 25% bamboo; 114 yd [105 m]/1¼ oz [50 g]; **(4)**): #02 banana cream (MC), 1 (1, 1, 2, 2) skeins. Elann.com Peruvian Quechua (65% alpaca, 35% Tencel; 122 yd [112 m]/1¼ oz [50 g]; **(3)**): #0100 parchment (CC), 1 skein.

HOOK Size D/3 (3.25 mm) or E/4

(3.5 mm) (see Notes). Adjust hook size if necessary to obtain correct gauge.

NEEDLES Size 7 (4.5 mm) 12- or 16-inch circular needles and set of 4 or 5 double-pointed (dpn). Adjust needle size if necessary to obtain correct gauge.

NOTIONS Stitch markers (m); yarn needle.

GAUGE Motif A = 2⅜" square on smaller hook and 2⅝" square on larger hook; motif B = 2½" square on larger hook; 24 sts and 26 rows = 4" in St st. **Note:** All gauge measurements after blocking.

NOTES

Use small hook for infant and teen size hat; use larger hook for toddler, child, and adult hat.

Hat is knit first, then motifs are worked and joined to a band. Motif band is joined to knitted hat with sc.

STITCH GUIDE

DC 2 CLUSTER (DC2CL): *Yo, insert hook in indicated sp and pull up lp, yo and draw through 2 lps; rep from * 1 time, yo and draw through all lps on hook.

STOCKINETTE ST (ST ST): Knit every rnd.

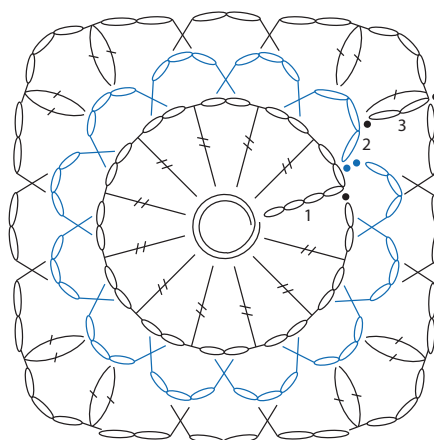
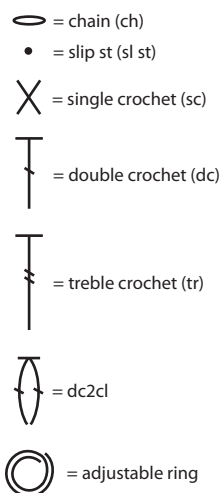

MOTIF A

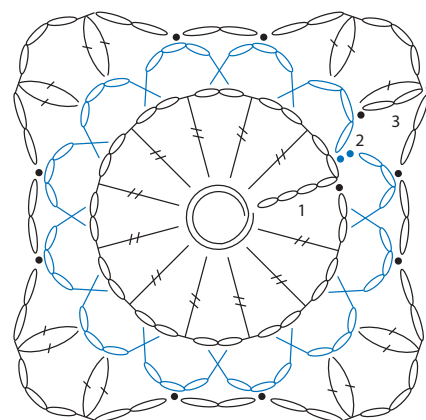

MOTIF B

MOTIF A

With CC, make adjustable ring (see Glossary).

Rnd 1: (RS) Ch 6 (counts as tr and ch 2), [tr in ring, ch 2] 11 times, sl st in 4th ch of beg ch-6 to join, pull tail to tighten ring—12 tr.

Rnd 2: Sl st in first ch-2 sp, [ch 3, sc in next ch-2 sp] 11 times, ch 3, sl st in beg sl st to join.

Rnd 3: Sl st in first ch-3 sp, ch 2, (dc, ch 3, dc2cl [see above]) in same ch-3 sp, [ch 2, sc in next ch-3 sp] 2 times, ch 2, *(dc2cl, ch 3, dc2cl) in next ch-3 sp, [ch 2, sc in next ch-3 sp] 2 times, ch 2; rep from * 2 times, sl st in first dc to join. Fasten off leaving 8" tail.

MOTIF B

With CC and larger hook, make adjustable ring.

Rnds 1–2: Work Rnds 1–2 of motif A.

Rnd 3: Sl st in first ch-3 sp, ch 2, (dc, ch 3, dc2cl) in same ch-3 sp, [ch 2, sl st in next ch-3 sp] 2 times, ch 2, *(dc2cl, ch 3, dc2cl) in next ch-3 sp, [ch 2, sl st in next ch-3 sp] 2 times, ch 2; rep from * 2 times, sl st in first dc to join. Fasten off leaving 8" tail.

Hat

With MC, CO 72 (80, 88, 96, 104) sts,

place marker (pm), join to knit in the rnd, being careful not to twist sts. Work in St st (see Stitch Guide) until piece measures 3½ (4½, 5, 5½, 6)" from CO edge. **BEG DEC:**

Rnd 1: *K6, k2tog (see Glossary); rep from * around—63 (70, 77, 84, 91) sts.

Rnd 2 and all even-numbered rnds: Knit.

Rnd 3: *K5, k2tog; rep from * around—54 (60, 66, 72, 78) sts.

Rnd 5: *K4, k2tog; rep from * around—45 (50, 55, 60, 65) sts.

Switch to double-pointed needles.

Rnd 7: *K3, k2tog; rep from * around—36 (40, 44, 48, 52) sts.

Rnd 9: *K2, k2tog; rep from * around—27 (30, 33, 36, 39) sts.

Rnd 11: *K1, k2tog; rep from * around—18 (20, 22, 24, 26) sts.

Rnd 13: K2tog around—9 (10, 11, 12, 13) sts.

Fasten off leaving 10" tail. Using yarn needle, thread tail through rem sts and pull tight to close. Fasten off and weave in loose ends.

Finishing

With larger hook and WS facing, join CC, and work 1 rnd of sc around edge

of hat working 1 sc in each knitted st—72 (80, 88, 96, 104) sc. Set aside. Work 7 B motifs (see Stitch Guide) for child's hat. Work 6 (6, 0, 8, 8) A motifs using appropriate hook size (see Notes). With WS of motifs facing and using yarn needle and CC, sew motifs tog into a band inserting needle through back lp only of motifs. With larger hook and RS of motif band facing, join CC yarn and work 1 rnd of sc around top edge of the band. Slip motif band over hat, matching the edge of the hat with bottom edge of the band. With larger hook and CC, work 1 rnd of sc along bottom edge of band while joining motif band to hat. With yarn needle and CC, join top edge of band to hat. Weave in loose ends.

ANASTASIA POPOVA is inspired by children who surround her in her work as a nanny, chemistry and math tutor, and crochet instructor. She has designed children's crocheted clothes and accessories for a local boutique. She founded www.crochetnj.com, a community for local crocheters to share their work.



Snowflake Sweater

by **MARI LYNN PATRICK**
Originally published in
Interweave Crochet Fall 2010

FINISHED SIZE 35 (37, 42, 43)" bust circumference. Garment shown measure 35", modeled with 1" negative ease.

YARN Manos del Uruguay Serena, (60% baby alpaca, 40% pima cotton; 156 yd [143 m]/1¼ oz [50 g]; **2**): #2246 light gray (A), 3 (3, 4, 4) skeins.
Manos del Uruguay Rittenhouse Merino 5-ply (100% wool; 241 yd [221 m]/¾ oz [100 g]; **4**): #531 med gray (B), 3 (4, 4, 5) skeins. Yarns distributed by Fairmount Fibers.

HOOK Size D/3 (3.25 mm). Adjust hook size if necessary to obtain correct gauge.

NEEDLE Sizes 8 (5 mm) and 7 (4.5 mm).

Adjust needle size if necessary to obtain correct gauge.

NOTIONS Waste yarn for stitch holder.

GAUGE 19 sts and 27 rows = 4" in St st using larger needles.

NOTES

On every rnd of medallion, work each dc in back lp only (blo).

When working medallion in rows, work each WS dc in front lp only.

STITCH GUIDE

SLOPED BIND-OFF (SLOPED BO): When working a series of BO rows, work first BO as written. On row before next BO

row, work to last st. Do not work last st, instead turn work. Wyb (see page 70), sl first st on left-hand (LH) needle purlwise to right-hand (RH) needle, then BO last st from previous row over slipped st.

BOBBLE ST: Working in both lps of st, [yo and pull up lp in next st, yo and draw through 2 lps] 6 times in same st, yo and draw through all 7 lps, ch 1 to tighten bobble st.

Note: On rnds foll bobble rnd, work FPdc around bobble to make bobble "pop" to RS. On the WS rows foll bobble rows, work BPdc around bobble to make

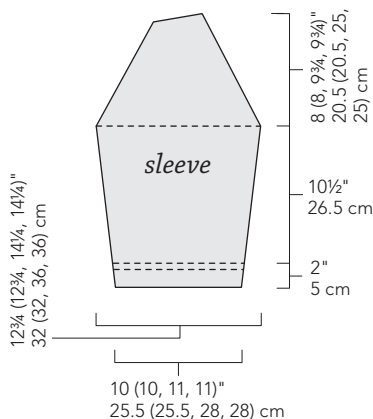
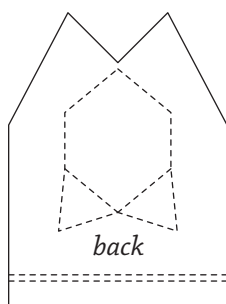
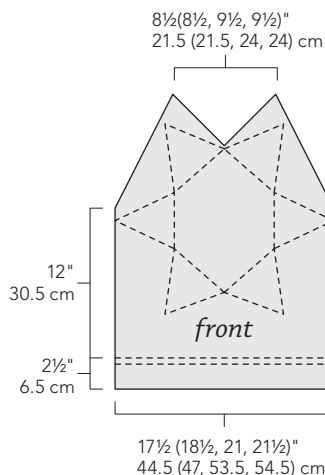

bobble “pop” to RS.

V-st: (Dc, ch 2, dc) in indicated sp.

CROCHET INSERT STRIPS

Row 1: (RS) With A, sc across, turn.

Row 2: With A, ch 4, sk first st, *dc in next st, ch 1, sk next st; rep from * across, turn.

Row 3: With B, 2 sc in each ch-1 sp across, turn.

Row 4: (WS) With B and WS facing, pick up and knit 1 st in each sc and sl to knitting needle to beg knitting. Forms a ridge on RS.

MEDALLION CENTER (MAKE 2)

With hook and A, ch 2, sl st in first ch to form ring.

Rnd 1: Ch 3, 17 dc in ring, sl st in top of beg ch-3 to join.

Rnd 2: Ch 5 (counts as dc and ch 2), [dc in next st, ch 2] 17 times, sl st in 3rd ch of beg ch-5 to join—18 ch-2 sps.

Rnd 3: Ch 3, 2 dc in first sp, [3 dc in next sp] 17 times, sl st in top of beg ch-3 to join—54 dc.

Rnd 4: Ch 3, working in back lps only (blo) on this and all foll rnds (see Notes), dc in next 7 sts, *V-st (see Stitch Guide) in next st, dc in next 8 sts; rep from * 5 more times, V-st in last st, sl st in top of beg ch-3 to join.

Rnd 5: Ch 3, dc in next 2 sts, *bobble (see Stitch Guide) through both lps of next st, dc in next st, 2 dc in next st, bobble, dc in next 3 sts, V-st in next ch-2 sp, dc in next 3 dc; rep from *, bobble, dc in next st, 2 dc in next st, bobble, dc in next 3 sts, V-st in last sp, sl st in top of beg ch-3 to join.

Rnd 6: Ch 3, dc in next 2 sts, *bobble, FPdc (see Glossary) around next bobble, dc in next st, bobble, dc in next st, FPdc around next bobble, dc in next st, bobble, dc in next 2 sts,

ch 2, sk next ch-2 sp, dc in next 3 dc; rep from *, ending last rep skipping last 3 dc.

Rnd 7: Ch 3, working FPdc around each bobble, dc blo in each dc around and V-st in each ch-2 sp, ending with V-st in last ch-2 sp, sl st in top of beg ch-3 to join—90 dc and 6 ch-2 sps.

Rnd 8: Ch 3, dc blo in each dc and V-st in each ch-2 sp—102 dc and 6 ch-2 sps.

SIZES 42 (43)" ONLY:

Rnds 9–10: Rep Rnd 8—126 dc and 6 ch-2 sps.

ALL SIZES:

Rnd 9 (9, 11, 11): Ch 3, dc in next 2 (2, 4, 4) dc, *bobble, [dc in next 4 dc, bobble] 2 times, dc in next 3 (3, 5, 5) dc, V-st in ch-2 sp, dc in next 3 (3, 5, 5) dc; rep from *, ending with V-st in last ch-2 sp, sl st in top of beg ch-3 to join—19 (19, 23, 23) sts bet each ch-2 sp.

Rnd 10 (10, 12, 12): Ch 3, dc in next 0 (0, 2, 2) dc, *bobble, [dc in next 4 dc, bobble] 3 times, dc in next 1 (1, 3, 3) dc, (dc, ch 2, dc) in next ch-2 sp, dc in next 2 (2, 4, 4) dc; rep from *, ending with V-st in last ch-2 sp—21 (21, 25, 25) sts bet each ch-2 sp.

Rnd 11 (11, 13, 13): Rep Rnd 8—23 (23, 27, 27) sts.

Rnd 12 (12, 14, 14): Ch 3, *2 dc in next st, dc to 1 st before next ch-2 sp, V-st in next ch-2 sp; rep from * around—27 (27, 31, 31) sts bet each ch-2 sp. Fasten off. **Note:** Crochet medallion measures 9 (9, 10½, 10½)" in diameter.

Front

FIRST SNOWFLAKE POINT: Working back and forth in rows, through blo on RS and flo on WS, work as foll:

Row 1: (RS) Join A in any ch-2 sp, ch 3, working in blo dc2tog (see Glossary), dc to last 3 sts before ch-2 sp,

dc2tog, dc in last dc, turn—25 (25, 29, 29) sts.

Row 2: (WS) Ch 3, working in flo dc2tog, work in dc to last 3 sts, dc2tog, dc in last dc, turn—23 (23, 27, 27) sts.

Row 3: Ch 3, dc2tog, dc in next 1 (1, 3, 3) dc, [bobble, dc in next 4 dc] 3 times, bobble, dc in next 0 (0, 2, 2) dc, dc2tog, dc in last dc, turn—21 (21, 25, 25) sts.

Row 4: Ch 3, dc2tog, dc in next 2 (2, 4, 4) dc, [bobble, dc in next 4 dc] 2 times, bobble, dc in next 2 (2, 4, 4) dc, dc2tog, dc in last dc, turn—19 (19, 23, 23) sts.

Rows 5–6: Rep Rows 1–2—15 (15, 19, 19) sts.

SIZES 42 (43)" ONLY:

Rows 7–8: Rep Rows 1–2—15 sts.

ALL SIZES:

Row 7 (7, 9, 9): Ch 3, dc2tog, bobble, dc in next 3 dc, bobble, dc in next 3 dc, bobble, dc2tog, turn—13 sts.

Row 8 (8, 10, 10): Ch 3, dc2tog, dc, bobble, dc in next 3 dc, bobble, dc in next dc, dc2tog, dc in last dc, turn—11 sts.

Row 9 (9, 11, 11): Ch 3, dc2tog, dc in next 7 dc, dc2tog, turn—9 sts.

Row 10 (10, 12, 12): Rep Row 9 (9, 11, 11)—7 sts.

Row 11 (11, 13, 13): Ch 3, [sk next st, yo, insert hook in next st and pull up lp, yo and draw through 2 lps] 3 times, yo and draw through all 4 lps on hook. Fasten off.

POINTS 2–6: Sl st in next ch-2 sp. Rep Rows 1–11 (11, 13, 13) of first snowflake point (see schematic). **FINISH MEDALLION CENTER:** Beg at top of first point, join A in ch-2 sp.

Row 1: *2 sc in next ch-2 sp, 25 (25, 29, 29) sc along side of point; rep from * 9 more times, ending at top of 6th point, 2 sc in final ch-2 sp, turn leaving rem 2 edges unworked.



Rows 2–3: Work Rows 2–3 of crochet insert strips (see Stitch Guide).

Beg knitted portion as foll:

Short-Row Filler 1: With WS facing, larger needles, and B, pick up and knit 55 (55, 59, 59) sts bet 6th and 5th point, mark center st. Work short-rows as foll (see Glossary):

Row 1: (RS) Knit to 2 sts before center st, s2kp2, k to last 3 sts, wrap and turn (w&t).

Row 2: Purl to last 3 sts, w&t.

Row 3: Knit to 2 sts before center st, s2kp, knit to 3 sts before wrapped st, w&t.

Row 4: Purl to 3 sts before wrapped st, w&t.

Rows 5–12: Rep Rows 3–4 four more times—43 (43, 47, 47) sts.

BO (see Glossary), working wraps tog with wrapped sts.

Short-Row Filler 2: Work as for Short-Row Filler 1.

Short-Row Filler 3: Work as for Short-Row Filler 1, sl 43 (43, 47, 47) sts to waste-yarn holder.

Short-Row Filler 4: Work as for Short-Row Filler 1, only cont to work short-rows for the right side seam as foll:

Row 1: Knit to the last 2 sts, w&t, purl to end.

Row 2: Knit to within 2 sts of previous wrapped st, w&t, purl to end.

Rows 3–10 (10, 14, 14): Rep Row 2.

BO, working wraps tog with wrapped sts. **Short-Row Filler 5:** Work as for Short-Row Filler 4 only reverse the short-rows by beg with a purl row not knit. **LOWER FRONT:** With RS facing, pick up and knit 20 (22, 26, 28) sts at the base of Short-Row Filler 5, k43 (43, 47, 47) from Short-Row Filler 3, pick up and knit 20 (22, 26, 28) sts at the base of Short-Row Filler 4—83 (87, 99, 103) sts.

Cont in St st (knit on RS, purl on WS) for 19 more rows. BO all sts. ****Work** crochet insert strip (see Stitch Guide), working 83 (87, 99, 103) sc along BO edge. Change to smaller needles, work in k1, p1 rib on 83 (87, 99, 103) sts for 8 rows. With larger needle, BO in patt**. Work crochet insert strip on short-row points 1 and 2. Sl 43 (43, 47, 47) sts to waste yarn for finishing later with sleeve.

Back

On back medallion (see schematic), work back points 1 and 2, foll instructions for front 1 point. Trim entire medallion with crochet insert. Work 1 short-row filler only, foll instructions for Short-Row Filler 3 of front. Sl these 43 (43, 47, 47) sts to waste yarn.

RIGHT BACK: Foll diagram, RS facing, with larger needles and B, and working only right edge of medallion and point, pick up and knit 50 (50, 58, 58) sts.



Row 1: (WS) P1, p2tog (see Glossary), purl to end.
Row 2: Knit to last 3 sts, k2tog, k1. Rep Rows 1–2 two more times—44 (44, 52, 52) sts. **Next row:** Purl across.
Next row: Rep Row 2. Rep last 2 rows 6 (7, 10, 12) more times—37 (36, 41, 39) sts. Work even in St st for 8 (10, 7, 5) rows. BO all sts. **LEFT BACK:** Foll diagram, with RS facing, larger needles and B, and working only left edge of the medallion and point, pick up and knit 50 (50, 58, 58) sts.
Row 1: (WS) Purl to last 3 sts, p2tog, p1.
Row 2: K1, K2tog, K to end. Rep Rows 1–2 two more times—44 (44,

52, 52) sts. **Next row:** Purl across, **Next row:** Rep Row 2. Rep last 2 rows 6 (7, 10, 12) more times—37 (36, 41, 39) sts. Work even in St st for 8 (10, 7, 5) rows. BO all sts. **LOWER BACK:** With RS facing, larger needles, and B, pick up and knit 20 (22, 26, 28) sts of left back, k43 (43, 47, 47) from Short-Row Filler 1, pick up and knit 20 (22, 26, 28) sts in right back—83 (87, 99, 103) sts. Work in St st until piece measures same as front to crochet insert. Rep from ** to ** of front crochet inserts to complete back.

Left Sleeve

Note: Crochet insert and ribbing will be worked later. With larger needles and B, CO 47 (47, 53, 53) sts. Work in St st, inc (k1f&b; see page 70) in first st and 2nd to last st on RS rows every 8th row 7 times—61 (61, 67, 67) sts. Work even until piece measures 10½" from beg, ending with a RS row. BO all sts. Work crochet insert on 61 (61, 67, 67) sts of BO edge. **SHAPE RAGLAN:** BO 4 sts at beg of next 2 rows. Work 2 rows even. **Dec row:** (RS) K2, ssk, knit to last 4 sts, k2tog, k2. Rep Dec row every 4th row 11 (11, 14, 14) more times, ending with a RS row—29 sts. **SHAPE CAP:** **Next row:** (WS) Using sloped method (see Stitch Guide), BO 7 sts at beg of next 3 WS rows. BO rem 8 sts. **CUFF:** Join in CO edge and work as for the lower front crochet insert and rib, on 47 (47, 53, 53) sts.

Right Sleeve

Work as for left sleeve to cap, ending

with a WS row. **Next row:** (RS) Using sloped method, BO 7 sts at beg of next 3 RS rows. BO rem 8 sts. Complete cuff as for left sleeve.

Finishing

Block all pieces to measurements. **SET IN SLEEVE:** With WS facing, pick up and knit 49 (49, 55, 55) sts along left-front armhole (including the side of the crochet insert). From the RS pick up and knit the same number of sts for the corresponding left raglan sleeve edge (including the BO sts). Using the three-needle BO (see Glossary), join sleeve to armhole. Rep for right-front armhole and left-back armhole. Leave final seam open. Work crochet insert around neck opening on 118 (118, 130, 130) sc. Work in k1, p1 rib on the 118 (118, 130, 130) sts for 5 rows. BO all sts. Sew neckband seam and join the final raglan seam as before. Using the crochet hook, sl st the side and sleeve seams tog.

MARI LYNN PATRICK has worked exclusively as a knit and crochet designer and writer since 1973. She lives in Baltimore, Maryland.



Mélangé Turtleneck

by **KATIE HIMMELBERG**

Originally published in
Interweave Crochet Winter 2007

FINISHED SIZE 34 (38, 42, 46, 50)" bust circumference. Garment shown measures 34". Fit is snug; allow 0–2" of negative ease.

YARN Blue Sky Alpacas Mélangé (100% baby alpaca; 110 yd [100 m]/1¼ oz [50 g];): #807 Dijon (A), 6 (7, 8, 10, 11) skeins and #802 pesto (B), 5 (7, 7, 8, 9) skeins.

HOOK SIZE G/7 (4 mm). Adjust hook size if necessary to obtain the correct gauge.

NEEDLES Sizes 2 (2.75 mm) and 3 (3.25 mm): 22" circular (cir). Adjust needle size if necessary to obtain the correct gauge.

NOTIONS Stitch markers (m); yarn needle; waste yarn.

GAUGE 24 sts and 32 rnds = 4" in St st in the rnd on larger needle. One perky sh patt rep = 2"; 4 rows = 1½".

SKILL LEVEL Intermediate.

STITCH GUIDE

PERKY SHELLS (perky sh; a multiple of 10 sts + 2)

Row 1: (RS) Sc in 2nd ch from hook, sc in next ch, ch 3, sk next 2 ch, dc in next ch, ch 1, sk next ch, dc in next ch, ch 3, *sk next 2 ch, sc in next ch, ch 1, sk next ch, sc in next ch, ch 3, sk next 2 ch, dc in next ch, ch 1, sk

next ch, dc in next ch, ch 3; rep from * to last 4 ch, sk next 2 ch, sc in rem 2 ch, turn.

Row 2: (WS) Ch 3 (counts as first dc here and through-out), dc in next sc, ch 3, sk next ch-3 sp, sc in next ch-1 sp, ch 3, *sk next ch-3 sp, dc in next ch-1 sp, [ch 1, dc in same sp] twice, ch 3, sk next ch-3 sp, sc in next ch-1 sp, ch 3; rep from * to last ch-3 sp, sk last ch-3 sp, dc in rem 2 sc, turn.

Row 3: Ch 3, dc in next dc, ch 3, sc in next ch-3 sp, ch 1, sc in next ch-3 sp, ch 3, *dc in next ch-1 sp, ch 1, dc in next ch-1 sp, ch 3, sc in next ch-3 sp, ch 1, sc in next ch-3 sp, ch 3; rep from

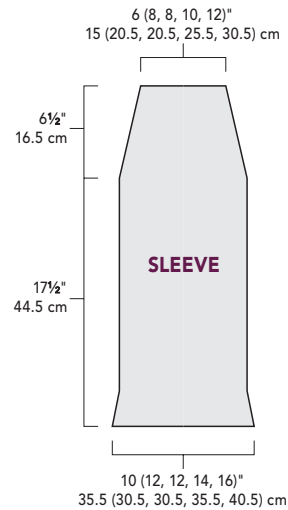
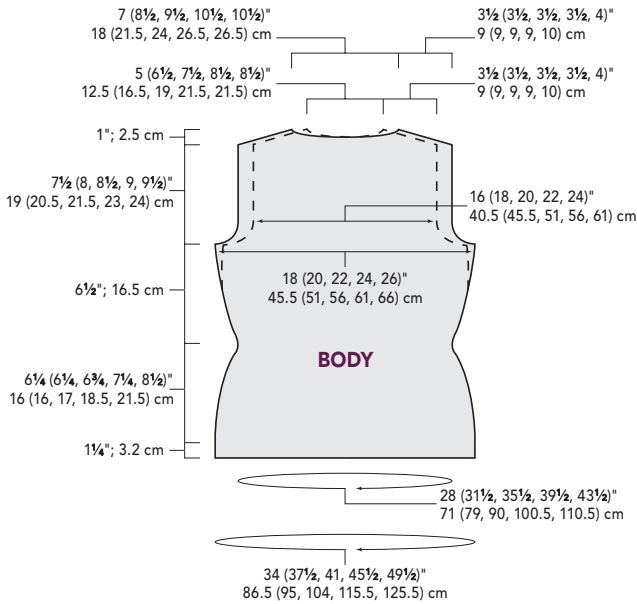

* to last 2 dc, dc in rem 2 dc, turn.

Row 4: Ch 1, sc in first 2 dc, ch 3, sk next ch-3 sp, dc in next ch-1 sp, [ch 1, dc in same sp] twice, ch 3, *sk next ch-3 sp, sc in next ch-1 sp, ch 3, sk next ch-3 sp, dc in next ch-1 sp, [ch 1, dc in same sp] twice, ch 3; rep from * to last ch-3 sp, sk last ch-3 sp, sc in rem 2 dc, turn.

Row 5: Ch 1, sc in first 2 sc, ch 3, sk next ch-3 sp, dc in next ch-1 sp, ch 1, dc in next ch-1 sp, ch 3, *sc in next ch-3 sp, ch 1, sc in next ch-3 sp, ch 3, dc in next ch-1 sp, ch 1, dc in next ch-1 sp, ch 3; rep from * to last ch-3 sp, sk last ch-3 sp, sc in rem 2 sc, turn.

Rep Rows 2–5 for patt.

Body

With A and smaller cir needle, CO 202 (225, 246, 273, 297) sts. Place marker (pm) to indicate beg of rnd and join, being careful not to twist sts. Work in St st (knit every rnd) for 10 rnds. Purl 1 rnd. Switch to larger cir needle and knit 10 rnds. Join CO edge to working rnd

to form hem by working every other stitch through both ends as foll: **NEXT RND:** fold up hem along purl line with WS tog so the CO edge lies parallel to needles. *K1, k2tog (insert left-hand needle in 1 st from CO edge, work as k2tog with live stitch on needle); rep from * around. Cont in St st until piece measures 3 (3, 3½, 4, 5)" from hem fold line, ending with a WS row. **SHAPE WAIST:** K27 (29, 32, 34, 38), ssk (see Glossary), pm, k50 (56, 62, 70, 74), pm, k2tog, k27 (29, 32, 34, 38), pm for side seam, k27 (29, 32, 34, 38), ssk, pm, k36 (45, 51, 59, 63), pm, k2tog, k27 (29, 32, 34, 38)—198 (221, 245, 269, 293) sts. *Work 2 rnds even. **DEC RND:** Knit to 2 sts before first m, ssk, sl m, knit to next m, sl m, k2tog, knit to next m, slip m (side seam m), knit to 2 sts before next m, ssk, sl m, knit to next m, sl m, k2tog, knit to end of rnd. Rep from * 7 more times (9 dec rnds worked)—166 (189, 213, 237, 261) sts rem. Work even in St st until piece measures 7½ (7½, 8, 8½, 9½)" from hem fold line. ***INC RND:** Knit to m, M1 (see

Glossary), sl m, knit to next m, sl m, M1, knit to next m, sl m (side seam m), knit to next m, M1, sl m, knit to next m, sl m, M1, knit to end of rnd. Work 2 rnds even. Rep from * 8 more times (9 inc rnds worked)—202 (225, 249, 273, 297) sts. Removing all m except beg-of-rnd m and side-seam m, work even until piece measures 14 (14, 14½, 15, 16)" from hem fold line.

Front

SHAPE ARMHOLES: BO 5 (5, 6, 7, 8) sts at beg of next rnd, knit to side-seam m, place rem 94 (107, 119, 131, 143) sts on holder for back. Begin working back and forth in rows as foll: **NEXT ROW:** (WS) BO 5 (5, 6, 7, 8) sts, purl to end of row. Dec 1 st each end of every other row 4 (5, 6, 7, 8) times, then every 4 rows 3 (3, 4, 5, 6) times as foll: (RS) K1, ssk, knit to last 3 sts, k2tog, k1—84 (92, 98, 104, 110) sts rem. Work even in St st until armholes measure 6 (6½, 7, 7½, 8)" ending with a WS row. **SHAPE NECK:** (RS) K33 (35, 37, 39, 41), attach new ball of yarn and BO center 18 (22,

24, 26, 28) sts, knit to end—33 (35, 37, 39, 41) sts rem each side. Working both sides separately at the same time, work one WS row even, then BO 2 sts at each neck edge 4 (5, 5, 5, 5) times. Dec 1 st at each neck edge every row 4 (4, 6, 8, 7) times, and at the same time, when armholes measure 7½ (8, 8½, 9, 9½)" and ending WS row begin shoulder shaping. **SHAPE SHOULDERS:** (RS) BO 4 (4, 4, 4, 5) sts at beg of next 2 rows, BO 5 sts at beg of next 2 rows, BO 5 (5, 5, 5, 7) sts at beg of next 2 rows, BO 7 sts at beg of next 2 rows.

Back

Place held sts on larger cir needle—94 (107, 119, 131, 143) sts. **SHAPE ARMHOLES:** (RS) BO 5 (5, 6, 7, 8) sts at beg of next 2 rows. Dec 1 st each end every other row 4 (5, 6, 7, 8) times, then every 4 rows 3 (3, 4, 5, 6) times as foll: (RS) K1, ssk, knit to last 3 sts, k2tog, k1—70 (81, 87, 93, 99) sts rem. Work even in St st until armholes measure 7½ (8, 8½, 9, 9½)", ending with a WS row. **SHAPE SHOULDERS AND NECK:** Mark center 28 (39, 45, 51, 51) sts. (RS) BO 4 (4, 4, 4, 5) sts at beg of next 2 rows, ending with a WS row. **NEXT ROW:** (RS) BO 5 sts, work to marked sts, join new ball of yarn and BO 28 (39, 45, 51, 51) sts, work to end. BO 5 sts at beg of next row, BO 5 (5, 5, 5, 7) sts at beg of next 2 rows, BO 7 sts at beg of next 2 rows.

Sleeves

NOTE: Sleeve is worked from the top down. Sleeve cap is inc'd to underarm, sleeve is worked even to cuff, then cuff is shaped.

With B, ch 32 (42, 42, 52, 52). Work in perky sh patt (see Stitch Guide) for 3 rows. **SHAPE CAP:**

Row 4: Ch 3, sc in 2nd and 3rd ch from hook, sc in first 2 dc, ch 3, sk next ch-3 sp, dc in next ch-1 sp, [ch 1, dc in same sp] twice, ch 3, *sk next ch-3 sp, sc in next ch-1 sp, ch 3, sk next

ch-3 sp, dc in next ch-1 sp, [ch 1, dc in same sp] twice, ch 3; rep from * to last ch-3 sp, sk last ch-3 sp, sc in rem 2 dc, turn.

Row 5: Ch 3, sc in 2nd and 3rd ch from hook, sc in first 2 sc, ch 3, sk next ch-3 sp, dc in next ch-1 sp, ch 1, dc in next ch-1 sp, ch 3, *sc in next ch-3 sp, ch 1, sc in next ch-3 sp, ch 3, dc in next ch-1 sp, ch 1, dc in next ch-1 sp, ch 3; rep from * to last ch-3 sp, sk last ch-3 sp, sc in rem 4 sc, turn.

Row 6: Ch 3, dc in next 3 sc, ch 3, sk next ch-3 sp, sc in next ch-1 sp, ch 3, *sk next ch-3 sp, dc in next ch-1 sp, [ch 1, dc in same sp] twice, ch 3, sk next ch-3 sp, sc in next ch-1 sp, ch 3; rep from * to last ch-3 sp, sk last ch-3, dc in last 4 sc, turn.

Row 7: Ch 3, dc in next 3 dc, ch 3, sc in next ch-3 sp, ch 1, sc in next ch-3 sp, ch 3, *dc in next ch-1 sp, ch 1, dc in next ch-1 sp, ch 3, sc in next ch-3 sp, ch 1, sc in next ch-3 sp, ch 3; rep from * to last 4 dc, dc in rem 4 dc, turn.

Row 8: Ch 3, sc in 2nd and 3rd ch from hook, sc in next 4 dc, ch 3, sk next ch-3 sp, dc in next ch-1 sp, [ch 1, dc in same sp] twice, ch 3, *sk next ch-3 sp, sc in next ch-1 sp, ch 3, sk next ch-3 sp, dc in next ch-1 sp, [ch 1, dc in same sp] twice, ch 3; rep from * to last ch-3 sp, sk last ch-3 sp, sc in rem 4 dc, turn.

Row 9: Ch 3, sc in 2nd and 3rd ch from hook, sc in next 4 sc, ch 3, sk next ch-3 sp, dc in next ch-1 sp, ch 1, dc in next ch-1 sp, ch 3, *sc in next ch-3 sp, ch 1, sc in next ch-3 sp, ch 3, dc in next ch-1 sp, ch 1, dc in next ch-1 sp, ch 3; rep from * to last ch-3 sp, sk last ch-3 sp, sc in rem 6 sc, turn (1 full rep inc'd; half on each side).

Row 10: Ch 5, sk next 2 sc, dc in next sc, [ch 1, dc in same sc] twice, ch 3, sk next ch-3 sp, sc in next ch-1 sp, ch 3, *sk next ch-3 sp, dc in next ch-1 sp, [ch 1, dc in same sp] twice, ch 3, sk next ch-3 sp, sc in next ch-1

sp, ch 3; rep from * to last ch-3 sp, sk last ch-3 sp, sk next 2 sc, dc in next sc, [ch 1, dc in same sc] twice, ch 3, dc in rem sc, turn.

Row 11: Ch 6, dc in next ch-1 sp, ch 1, dc in next ch-1 sp, ch 3, *sc in next ch-3 sp, ch 1, sc in next ch-3 sp, ch 3, dc in next ch-1 sp, ch 1, dc in next ch-1 sp, ch 3; rep from * to last dc, dc in rem dc, turn.

Row 12: Ch 3, sc in 2nd and 3rd ch from hook, sc in next dc, ch 3, sc in next ch-1 sp, ch 3, dc in next ch-1 sp, [ch 1, dc in same sp] twice, ch 3, *sk next ch-3 sp, sc in next ch-1 sp, ch 3, sk next ch-3 sp, dc in next ch-1 sp, [ch 1, dc in same sp] twice, ch 3; rep from * to last dc, sc in last dc, turn.

Row 13: Ch 3, sc in 2nd and 3rd ch from hook, ch 3, sc in next ch-3 sp, ch 1, sc in next ch-3 sp, ch 3, *dc in next ch-1 sp, ch 1, dc in next ch-1 sp, ch 3, sc in next ch-3 sp, ch 1, sc in next ch-3 sp, ch 3; rep from * to last 3 sc, sc in rem 3 sc, turn.

Row 14: Ch 3, dc in next 2 sc, ch 3, sk next ch-3 sp, dc in next ch-1 sp, [ch 1, dc in same sp] twice, ch 3, sk next ch-3 sp, *sc in next ch-1 sp, ch 3, sk next ch-3 sp, dc in next ch-1 sp, [ch 1, dc in same sp] twice, ch 3, sk next ch-3 sp; rep from * to last 3 sc, dc in rem 3 sc, turn.

Row 15: Ch 3, dc in next 2 dc, ch 3, sk next ch-3 sp, dc in next ch-1 sp, ch 1, dc in next ch-1 sp, ch 3, *sc in next ch-3 sp, ch 1, sc in next ch-3 sp, ch 3, dc in ch-1 sp, ch 1, dc in next ch-1 sp, ch 3; rep from * to last ch-3 sp, sk last ch-3 sp, dc in rem 3 dc, turn.

Row 16: Ch 3, sc in 2nd and 3rd ch from hook, sc in next 3 dc, ch 3, sk next ch-3 sp, sc in next ch-1 sp, ch 3, sk next ch-3 sp, *dc in next ch-1 sp, [ch 1, dc in same sp] twice, ch 3, sk next ch-3 sp, sc in next ch-1 sp, ch 3, sk next ch-3 sp; rep from * to last 3 dc, sc in rem 3 dc, turn.

Row 17: Ch 3, sc in 2nd and 3rd ch from hook, sc in next 3 sc, ch 3, sc



in next ch-3 sp, ch 1, sc in next ch-3 sp, ch 3, *dc in next ch-1 sp, ch 1, dc in next ch-1 sp, ch 3, sc in next ch-3 sp, ch 1, sc in next ch-3 sp, ch 3; rep from * to last 5 sc, sc in rem 5 sc, turn.

Row 18: Ch 3, dc in first sc, ch 3, sk next 2 sc, sc in next sc, ch 3, sk next ch-3 sp, dc in next ch-1 sp, [ch 1, dc in same sp] twice, ch 3, sk next ch-3 sp, *sc in next ch-1 sp, ch 3, sk next ch-3 sp, dc in next ch-1 sp, [ch 1, dc in same sp] twice, ch 3, sk next ch-3 sp; rep from * to last 5 sc, sk next sc, sc in next sc, ch 3, 2 dc in rem sc, turn (2 full reps inc'd; 1 on each side).

Cont in perky sh patt, starting with Rows 3–5, then working Rows 2–5 eleven more times. **NOTE:** To adjust length of sleeve, add or remove a rep of Rows 2–5 here; each rep adds about 1½".

SHAPE CUFF: Cont in perky sh patt, working all "ch-3" as "ch-4" except for tch. Work Rows 2–5 once, then work Rows 2–4 once more.

Finishing

With yarn threaded on yarn needle, sew shoulder seams. **COLLAR:** With WS facing, B, and beg at front left side of neck, sc 85 (95, 105, 115, 125) evenly around neck opening, then ch 7—92 (102, 112, 122, 132) sts. Work Rows 1–5 of perky sh patt once, then work Rows 2–5 three more times. Fasten off. Wet-block pieces to measurements, pinning out lace on sleeves and collar. With yarn threaded on yarn needle, sew sleeve seams. Sew in sleeves. Sew ch-7 of right side of collar overlapping the left side of collar. With B, sew buttons to collar, using holes created by patt as buttonholes.

KATIE HIMMELBERG appreciates the strengths of crochet and knitting and enjoys projects that celebrate both. She mixes knit and crochet from her home in Loveland, Colorado.



BFF Finger Puppets

by **MARCY SMITH**
Originally published in
Interweave Knits Summer 2010

FINISHED SIZE 3¾" tall.

YARN Spud & Chloë Fine (80% superwash wool, 20% silk, 248 yd [227 m]/65 g): #7808 sassafras (pink; A), #7803 dachshund (brown; B), #7800 popcorn (white; C), and #7805 anemone (blue; D), 1 skein each. Yarn distributed by Blue Sky Alpacas.

HOOKS AND NEEDLES *Pinki*: size C/2 (2.75 mm) crochet hook; *Blu*: size 3 (3.25 mm): double-pointed needles (dpn) and size C/2 (2.75 mm) crochet hook. Adjust needle or hook size if necessary to obtain the correct gauge.

NOTIONS Markers (m); tapestry needle; small amount of fiberfill.

GAUGE 32 sts and 40 rows = 4" in St st on needles; 28 sts and 24 rows = 4" in sc.

STITCH GUIDE

Increase in single crochet (inc in sc): Sc in next st, sc again in same st—1 st inc'd.

NOTES

- *Pinki* is crocheted and *Blu* is knitted.
- Both dolls are worked in one piece from the hem of the dress to the top



Pinki

Note: Doll is worked from the RS; do not turn. For dress portion, join each rnd with a sl st in first st; this prevents a color jog in the stripes. Work the head in a spiral, without joining. For both methods, mark the first st with a removable marker. **DRESS:** With A, ch 30, join with sl st in first ch, being careful not to twist chains.

Rnd 1: Ch 1, sc in each ch around (30 sc), join with sl st in first sc, pulling B through sl st.

Rnd 2: With B, *sc in each of next 4 sts, sc2tog (see Glossary); rep from * around, join with sl st in first sc, pulling A through sl st—25 sc rem.

Rnd 3: With A, sc in each sc around, join with sl st in first st, pulling B through sl st.

Rnd 4: With B, *sc in each of next 3 sts, sc2tog; rep from * around, join with sl st in first sc, pulling A through sl st—20 sc rem.

Rnd 5: With A, sc in each sc around, join with sl st in first st, pulling B through sl st.

Rnd 6: With B, *sc in each of next 3 sts, sc2tog; rep from * around, join with sl st in first sc, pulling A through sl st—16 sc rem.

Rnds 7–13: With A, sc in each sc around, join with sl st in first st.

Rnd 14: [Sc2tog] around, joining C in sl st—8 sc rem.

Rnd 15: With C, sc in each sc around.

Rnd 16: 2 sc in each sc around—16 sc.

Rnd 17: Sc in each sc around.

Rnd 18: *Sc in next sc, inc in sc (see Stitch Guide); rep from * around—24 sc.

Rnds 19–23: Sc in each sc around

Rnd 24: *Sc in next sc, sc2tog; rep from * around—16 sc rem.

Rnd 25: Sc in each sc around.

Rnd 26: [Sc2tog] around—8 sc rem.

Rnd 27: [Sc2tog] around—4 sc rem. Cut yarn. Fasten off. Thread tail on tapestry needle and use to draw top of head tog. Stuff head with fiberfill through neck opening. With D, embroider eyes with satin st (see below). With A, embroider mouth with backstitch (see Glossary). **ARMS:** Join A with sl st on side of body about 4 rows down from neck (see photo). Ch 13, turn, sl st in 2nd ch from hook and each ch across. Cut yarn and fasten off. Thread yarn ends on tapestry needle and pull to inside. Tie ends tog and clip. Rep for other arm. **HAIR:** Cut 25–30 strands of B and about 6 strands of A each 12" long (or desired length). Fold a yarn strand in half, use hook to pull loop under a st on head; pull both ends through loop and tighten. Rep with rem strands to fill in hair. **HAT:** With A, ch 24. Join with sl st to first chain, being careful not to twist.

Rnds 1–3: Sc in each sc around. Press hat tog so front and back are flat, sl st across top of hat, matching front and back sts (12 sl st). Cut yarn. Place hat on doll and use yarn ends to tack hat down.

Blu

DRESS: With D, CO 45 sts. Distribute evenly over 3 dpn, place marker (pm), and join in the rnd.

Rnds 1–3: Knit.

Rnd 4: *K3, k2tog; rep from * around—36 sts rem.

Rnds 5–6: Knit.

Rnd 7: *K2, k2tog; rep from * around—27 sts rem.

Rnd 8: Knit.

Rnd 9: *K1, k2tog; rep from * around—18 sts rem.

Rnds 10–19: Knit.

of the head. Pinki's arms are worked from a slip-stitch join to the body; Blu's arms are worked separately in I-cord and attached. The edge of Blu's dress has a crocheted border to help the hem lie flat. To make her completely knitted, work three rows of garter stitch at the beginning of the dress, in MC or CC. To do this, purl one round, knit one round, purl one round, then resume; knit one row with MC before working decrease row.

- See Glossary for all crochet terms.



Rnd 20: [K2tog] around—9 sts rem.

Rnd 21: With D, knit.

Rnd 22: K1f&b in each st around—18 sts.

Rnd 23: Knit.

Rnd 24: *K1, k1f&b; rep from * around—27 sts.

Rnds 25–31: Knit.

Rnd 32: *K1, k2tog; rep from * around—18 sts rem.

Rnd 33: *K1, k2tog; rep from * around—12 sts rem.

Rnd 34: [K2tog] around—6 sts rem. Cut yarn. Thread tail on tapestry needle, run through rem 6 sts, and cinch to close. Stuff head with fiberfill through neck opening. With D, embroider eyes with satin st (see previous page). With A, embroider mouth with backstitch (see Glossary). **ARMS:** (make 2) CO 2 sts. Work 12-row 1-cord (see Glossary). **Next rnd:** K2tog. Fasten off rem st. Weave beg tail through arm.

Thread yarn ends through body at arm placement (see photo) and tie ends tog.

HAIR: Cut about 15 strands of B and D each 6" long (or desired length). Thread a strand of B and D tog on tapestry needle. Insert needle under st on head and pull yarn halfway through. Remove needle. Tie yarns into square knot, snug against head. Rep with rem hair, filling in as desired. **DRESS TRIM:** With hook, join A at hem with sl st. Work sc in joining st, *ch 1, sk 1 knit st, sc in next st; rep from * around, end with sc in final st, sl st in first sc. Cut yarn and fasten off. Weave in ends. **WAIST TRIM:** Cut 6" strand of A, weave over and under sts at waist. Pull ends to inside and tie off.

Marcy Smith is editor of Interweave Crochet. You may be familiar with Wimi, her small knitted companion, who has been featured in newspaper columns and craft blogs alike.

Crochet Basics

ABBREVIATIONS

beg	begin(s); beginning
bet	between
blo	back loop only
CC	contrasting color
ch	chain
cm	centimeter(s)
cont	continue(s); continuing
dc	double crochet
dtr	double treble crochet
dec(s)('d)	decrease(s); decreasing; decreased
est	established
fdc	foundation double crochet
flo	front loop only
fol	follows; following
fsc	foundation single crochet
g	gram(s)
hdc	half double crochet
inc(s)('d)	increase(s); increasing; increased
k	knit
lp(s)	loop(s)
MC	main color
m	marker
mm	millimeter(s)
patt(s)	pattern(s)
pm	place marker
p	purl
rem	remain(s); remaining
rep	repeat; repeating
rev sc	reverse single crochet
rnd(s)	round(s)
RS	right side
sc	single crochet
sk	skip
sl	slip
sl st	slip(ped) stitch
sp(s)	space(s)
st(s)	stitch(es)
tch	turning chain
tog	together
tr	treble crochet
WS	wrong side
yd	yard
yo	yarn over hook
*	repeat starting point
()	alternate measurements and/or instructions
[]	work bracketed instructions a specified number of times

Chain (ch)

Make a slipknot on hook, *yarn over and draw through loop of slipknot; repeat from * drawing yarn through last loop formed.



Slip Stitch (sl st)

*Insert hook in stitch, yarn over and draw loop through stitch and loop on hook; repeat from *.



Single Crochet (sc)

*Insert hook in stitch, yarn over and pull up loop (Figure 1), yarn over and draw through both loops on hook (Figure 2); repeat from *.

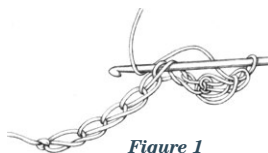

Figure 1

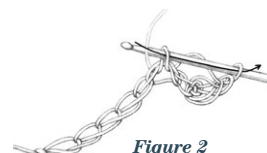

Figure 2

Double Crochet (dc)

*Yarn over, insert hook in stitch, yarn over and pull up loop (3 loops on hook; Figure 1), yarn over and draw through 2 loops (Figure 2), yarn over and draw through remaining 2 loops (Figure 3); repeat from *.



Figure 1

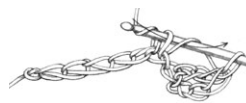

Figure 2

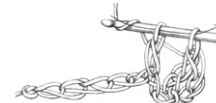

Figure 3

Adjustable ring

Place slipknot on hook, leaving a 4" tail. Wrap tail around fingers to form ring. Work stitches of first round into ring. At end of first round, pull tail to tighten ring.

Back Post Single Crochet (BPsc)

Insert hook from back to front to back around post of corresponding stitch below, yarn over and pull up loop, yarn over and draw through 2 loops on hook.

Crochet Gauge

To check gauge, chain 30 to 40 stitches using recommended hook size. Work in pattern stitch until piece measures at least 4" (10 cm) from foundation chain. Lay swatch on flat surface. Place a ruler over swatch and count number of stitches across and number of rows down (including fractions of stitches and rows) in 4" (10 cm). Repeat two or three times on different areas of swatch to confirm measurements. If you have more stitches and rows than called for in instructions, use a larger hook; if you have fewer, use a smaller hook. Repeat until gauge is correct.

Single Crochet Two Together (Sc2tog)

Insert hook in next stitch, yarn over, draw loop through stitch (two loops on hook, Figure 1). Insert hook in next stitch, yarn over, draw loop through stitch (three loops on hook). Yarn over and draw yarn through all three loops on hook (Figure 2). Completed sc2tog—one stitch decreased (Figure 3).



Figure 1



Figure 2



Figure 3

Front Post Double Crochet (FPdc)

Yarn over, insert hook from front to back to front around post of stitch to be worked, yarn over and pull up loop [yarn over and draw through 2 loops on hook] 2 times.

Double Crochet Two Together (dc2tog)

[Yarn over, insert hook in next stitch, yarn over and pull up loop, yarn over and draw through 2 loops] 2 times, yarn over and draw through all loops on hook—1 stitch decreased.



Knit Basics

ABBREVIATIONS

CO	cast on
k	knit
k1f&b	knit into front and back of same st
k2tog	knit two stitches together
knwise	knitwise
p	purl
p1f&b	purl into front and back of same st
p2tog	purl two stitches together
psso	pass slipped stitch over
p2sso	pass two slipped stitches over
pwise	purlwise
rev St st	reverse stockinette stitch
rib	ribbing
sl st	slip stitch (sl 1 st pwise unless otherwise indicated)
ssk	slip 1 knwise, slip 1 knwise, k2 sl sts tog tbl (decrease)
ssp	slip 1 knwise, slip 1 knwise, p2 sl sts tog tbl (decrease)
St st	stockinette stitch
tbl	through back loop
wyb	with yarn in back
wyf	with yarn in front

Knit Stitch (k)

With yarn held to the back of the work, insert the right needle into the first stitch on the left needle from bottom of the stitch to top and from the front of the stitch to the back. Wrap yarn around right-needle tip counterclockwise. Slip the right needle back through the stitch, carrying the wrapped yarn with it, then drop the worked stitch off the left needle. Gently tighten the yarn. One knit stitch completed on right needle.



Purl Stitch (p)

With yarn held to the front of the work, insert the right needle into the first stitch on the left needle from the top of the stitch to the bottom and from the back of the stitch to the front. Wrap the yarn around the right-needle tip counterclockwise. Draw the right needle back through the stitch carrying the wrapped yarn with it, drop the worked stitch of the left needle and gently tighten the yarn. One purl stitch completed on right needle.

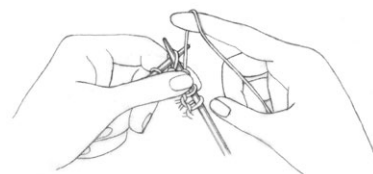

Cable Cast-On

Begin with a slipknot and one knitted cast-on stitch if there are no established stitches. Insert right needle between first two stitches on left needle (Figure 1). Wrap yarn as if to knit. Draw yarn through to complete stitch (Figure 2) and slip this new stitch to left needle as shown (Figure 3).

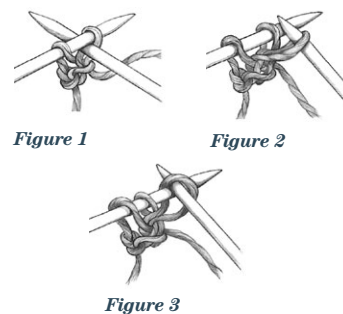

Continental (Long-Tail) Cast-On

Leaving a long tail (about ½" to 1" for each stitch to be cast on), make a slipknot and place on right needle. Place thumb and index finger of left hand between yarn ends so that working yarn is around index finger and tail end is around thumb. Secure ends with your other fingers and hold palm upward, making a V of yarn (Figure 1). Bring needle up through loop on thumb (Figure 2), grab first strand around index finger with needle, and go back down through loop on thumb (Figure 3). Drop loop off thumb and, placing thumb back in V configuration, tighten resulting stitch on needle (Figure 4).

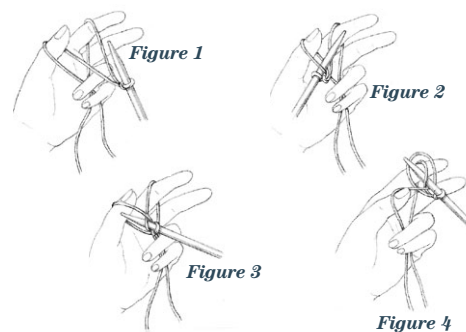

Purl 2 together (p2tog)

Purl two stitches together as if they were a single stitch.

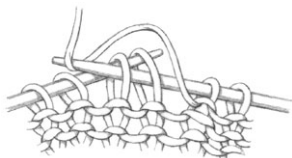

Knit 2 together (k2tog)

Knit two stitches together as if they were a single stitch.

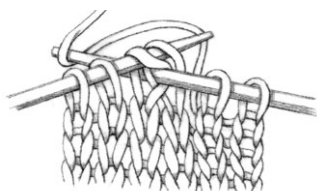

Ssk Decrease

Slip two stitches knitwise one at a time (Figure 1). Insert point of left needle into front of two slipped stitches and knit them together through back loops with right needle (Figure 2).



Figure 1

Figure 2

Backstitch Embroidery



I-Cord

With double-pointed needle, cast on desired number of stitches. *Without turning the needle, slide the stitches to other end of the needle, pull the yarn around the back, and knit the stitches as usual; repeat from * for desired length.



Raised (M1) Increases

Left Slant (M1L) With left needle tip, lift strand between needles from front to back (Figure 1). Knit lifted loop through the back (Figure 2).



Figure 1

Figure 2

Right Slant (M1R) With left needle tip, lift strand between needles from back to front (Figure 1). Knit lifted loop through the front (Figure 2).

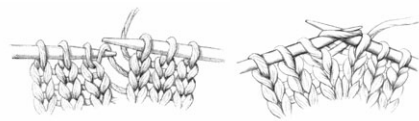

Figure 1

Figure 2

Short-Rows: Wrapping a Stitch

Work to turn point, slip next stitch purlwise to right needle. Bring yarn to front (Figure 1). Slip same stitch back to left needle (Figure 2). Turn work and bring yarn in position for next stitch, wrapping the stitch as you do so. Note: Hide wraps in a knit stitch when right side of piece is worked in a knit stitch. Leave wrap if the purl stitch shows on right side. Hide wraps as follows: Knit stitch: On right side, work to just before wrapped stitch. Insert right needle from front, under the wrap from bottom up, and then into wrapped stitch as usual. Knit them together, making sure new stitch comes out under wrap. Purl stitch: On wrong side, work to just before wrapped stitch. Insert right needle from back, under wrap from bottom up, and put on left needle. Purl them together.



Figure 1



Figure 2

Twisted Cord

Cut several lengths of yarn about five times the desired finished cord length. Fold the strands in half to form two equal groups. Anchor the strands at the fold by looping them over a doorknob. Holding one group in each hand, twist each group tightly in a clockwise direction until they begin to kink. Put both groups in one hand, then release them, allowing them to twist around each other counterclockwise. Smooth out the twists so that they are uniform along the length of the cord. Knot the ends.

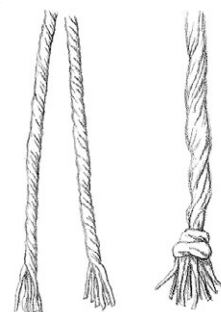

Figure 1

Figure 2

Standard Bind-Off (BO)

Knit the first stitch, *knit the next stitch (2 stitches on right needle), insert left needle tip into first stitch on right needle (Figure 1) and lift this stitch up and over the second stitch (Figure 2) and off the needle (Figure 3). Repeat from * for the desired number of stitches.



Figure 1



Figure 2



Figure 3

Satin Stitch

This stitch is ideal for filling in open areas, such as the center of leaves or flowers. Work closely spaced straight stitches (see Glossary), in graduated lengths as desired, and entering and exiting in the center of or at the side of the crocheted or knitted stitches.



Three-Needle Bind-Off

Place stitches to be joined onto two separate needles. Hold them with right sides of knitting facing together. Insert a third needle into first stitch on each of the other two needles and knit them together as one stitch. *Knit next stitch on each needle the same way. Pass first stitch over second stitch. Repeat from * until one stitch remains on third needle. Cut yarn and pull tail through last stitch.

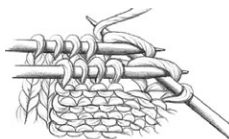

Kitchener Stitch

STEP 1: Bring threaded needle through front stitch as if to purl and leave stitch on needle.

STEP 2: Bring threaded needle through back stitch as if to knit and leave stitch on needle.

STEP 3: Bring threaded needle through same front stitch as if to knit and slip this stitch off needle. Bring threaded needle through next front stitch as if to purl and leave stitch on needle.

STEP 4: Bring threaded needle through first back stitch as if to purl (as illustrated), slip this stitch off, bring needle through next back stitch as if to knit, leave this stitch on needle.

Repeat Steps 3 and 4 until no stitches remain on needles.

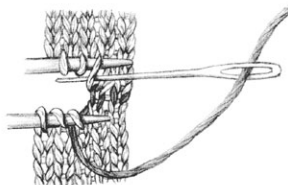

Illustrations by Gayle Ford