

---

CROCHET COWLS:  
**5 Free**  
*Crochet Cowl*  
*Patterns*

---



**crochetme**  
linking the crochet community

# CROCHET COWLS: 5 Free Crochet Cowl Patterns

CROCHET COWLS are the perfect addition to your accessory collection. They are warm; they add a pop of desired color and texture; and because they are a circle, not wrapped around your neck like a scarf, they won't loosen or tighten.

In this free eBook, we have gathered five crochet cowl patterns. You will find a variety of styles and techniques, from the Tunisian crochet of the Persimmon Cowl to the delicate shell stitches of the Lady Blue Warmer. The Rocksteady Cowl is perfect for warm weather or can be wrapped multiple times for chillier temperatures while the Fossil Neckwarmer is designed for warmth. Check out the innovative crochet cowls in this eBook.

The **Persimmon Cowl** by Dora Ohrenstein is worked in Tunisian crochet for a wonderfully warm and cozy crochet cowl. Tunisian knit stitches increase gradually from the neck down through the yoke, making this an easy crochet cowl pattern. The piece is worked flat and finished with a single seam.

The **Lady Blue Warmer** by Renee Banes is part shawllette, part poncho, part snood, and part cowl. Crocheted in extra fine wool, this shell patterned lace cowl is surprisingly warm. Sparkling beads are crocheted at the edging to give the crochet cowl pattern additional weight to help it fit just right.

The **Royal Mitts & Cowl** by Rebekah Thompson are worked in the round. A combination of Tunisian simple stitches and Tunisian purl stitches create a gorgeous honeycomb design that is perfect for this crochet cowl pattern.

The **Fossil Neckwarmer** by Kathy Merrick works up quickly in a bulky yarn, making it a great gift option. Created from joined circles, this cowl and the subtle design created by the yarn, reminded Kathy of the fossils of ancient creatures left behind in rocks.

The **Rocksteady Cowl** by Sharon Zientara combines chevron crochet with eye-catching stripes to create a fun crochet cowl. You can wear this cowl in on long loop or doubled. This is also a fabulous cowl option for warmer days.

Find the perfect crochet cowl to add to your wardrobe with *Crochet Cowls: 5 Free Crochet Cowl Patterns*. Share photographs of your finished project in the Crochet Me member Gallery and be sure to let your friends know about this fun new crochet Book.

Best wishes,

P.S. Do you have a friend who would love to add a few stylish crocheted cowls to their wardrobe? Send them the link to download their own copy of *Crochet Cowls: 5 Free Crochet Cowl Patterns*.

---

1	<b>Persimmon Cowl</b> . . . . .	page 3
2	<b>Lady Blue Warmer</b> . . . . .	page 4
3	<b>Royal Mitts and Cowl</b> . . . . .	page 5
4	<b>Rocksteady Cowl</b> . . . . .	page 6
5	<b>Fossil Neckwarmer</b> . . . . .	page 10
	<b>Abbreviations and Glossary</b> . . . . .	page 13

**crochetme**

CROCHET COWLS:  
5 FREE CROCHET COWL PATTERNS

A CROCHET ME E-BOOK EDITED BY  
**Toni Rexroat**

EDITORIAL STAFF  
EDITOR CROCHET ME **Toni Rexroat**

CREATIVE SERVICES  
PRODUCTION DESIGNER **Nichole Mulder**  
PHOTOGRAPHY **As noted**  
ILLUSTRATION **Gayle Ford**

©F+W Media, Inc. All rights reserved. F+W Media grants permission for any or all pages in this issue to be copied for personal use.



## Persimmon Cowl

Dora Ohrenstein



### TUNISIAN

#### Getting Started

**FINISHED SIZE** 17" circumference at top, 30" circumference at bottom, 6½" length from top to bottom. One size fits most.

**YARN** Madelinetosh Tosh Merino DK (100% superwash merino; 225 yd [206 m]/3½ oz [100 g]; **43**): warm maize, 1 skein.

**HOOK** Sizes K/10½ (6.5 mm) Tunisian hook, H/8 (5 mm) regular crochet hook.

**NOTIONS** 3 st markers (m); yarn needle.

**GAUGE** 16 tks and 16 rows = 4".

#### Notes

Lp on hook at beg of each row counts as first st.

Tks sts next to puffs and bobbles will enlarge and stretch of their own accord, giving the fabric an organic quality. Don't try to make them even with the smaller sts around them.

Inc are staggered to create a rounded edge at bottom of cowl.



PHOTOS BY NATHAN REGA, HARPER POINT PHOTOGRAPHY

#### Stitch Guide

**Puff:** **Note:** Work with loose tension. (Yo, insert hook as for tks and pull up lp to about ½") 5 times, yo and draw through 10 lps on hook, leave one lp on hook.

**Bobble:** (Yo, insert hook as for tss, pull up lp, yo and draw through 2 lps) 5 times, yo and draw through 5 lps on hook, leave one lp on hook. **Note:** Pop bobbles through to front of work after completing row.

#### For gauge swatch:

With regular hook, ch 24.

**Foundation row:** With Tunisian hook, pull up lp in back lp of 2nd ch from hook and in each ch across; RetP (see Glossary)—24 sts.

**Rows 1–20:** Tks (see Glossary) across; RetP.

#### Pattern

### COWL

With regular hook, ch 68.

**Foundation Row:** With Tunisian hook, pull up lp blo in 2nd ch from hook and in each ch across; RetP (see Glossary)—68 sts.

**Rows 1–2:** Tks (see Glossary) across; RetP.

**Row 3:** Tks in next 4 sts, \*puff (see Stitch Guide) in next st, tks in next 3 sts; rep from \* until 3 tks rem, tks in last 3 sts; RetP—15 puff sts.

**Row 4:** Tks in next 6 sts, \*puff in next st, tks in next 3 sts; rep from \* to last st, tks in last st; RetP—15 puff sts.

**Rows 5–11:** Tks across; RetP.

**Rows 12–13:** Rep Rows 3–4.

**Row 14:** Tks across; RetP.

**Row 15:** Tks in next 3 sts, M1 (see Glossary), [tks in next 8 sts, M1] 5 times, tks to end; RetP—74 sts.

**Row 16:** Tks in next 6 sts, M1, [tks in next 8 sts, M1] 8 times, tks to end; RetP—83 sts.

**Row 17:** Tks in next 4 sts, M1, [tks in next 5 sts, M1] 15 times, tks to end; RetP—99 sts.

**Row 18:** Tks in next 2 sts, M1, [tks in next 5 sts, M1] 18 times, tks to end; RetP—118 sts.

**Row 19:** Tks in next st, \*puff in next st, tks in next 3 sts; rep from \* across; RetP—29 puff sts.

**Row 20:** Tks in next 3 sts, \*puff in next st, tks in next 3 sts; rep from \* to last 2 sts, puff in next st, tks in last st; RetP—28 puff sts.

**Row 21:** Tks across; RetP.

**Row 22:** Tks in next st, \*bobble in next st, tks in next 3 sts; rep from \* across; RetP—29 bobble sts.

**Row 23:** With regular crochet hook, Tunisian BO (see Glossary), working tight enough to make bobbles pop out of texture. Fasten off, leaving 18" tail. With yarn needle and tail, sew seam. ❁

DORA OHRENSTEIN, author of *Creating Crochet Fabric* (Lark, 2010), frequently writes on crochet history and technique. She publishes the online magazine *Crochet Insider* ([www.crochetinsider.com](http://www.crochetinsider.com)).



## Lady Blue Warmer

Reneé Barnes



### Getting Started

**FINISHED** Size 27" long, 28" circumference at top, 64" circumference around bottom edge. One size fits most.

**YARN** Filatura Di Crosa Zara Centolavaggi (100% extrafine merino superwash; 1531 yd [1400 m]/3½ oz [100 g]; ): #1468 heather gray, 2 hanks. Yarn distributed by Tahki-Stacy Charles Inc.

**HOOK** Sizes E/4 (3.5 mm), C/2 (2.75 mm). Adjust hook size if necessary to obtain correct gauge.

**NOTIONS** Yarn needle; 40 beads; large-eye beading needle.

**GAUGE** 2 patt reps = 3"; 7 rnds = 4".

### Notes

Cape beg at bottom of ponchette and works upward to top of cowl, decreasing size by working with smaller hook and decreasing the size of sh worked. Yarn is joined for cowl, which is worked upward in joined rnds. Beaded trim in worked around bottom edge.

### Stitch Guide

**Beg Popcorn (bpc):** Ch 3, 4 dc in same st as join, remove hook, insert in top of tch, pull lp from 4th dc through top of tch.

**Popcorn (pc):** 5 dc in indicated st, remove hook, insert in top of first dc, pull lp from 5th dc through top of first dc.

**Shell (sh):** Work number of tr specified in st indicated.

### Pattern

#### PONCHETTE

**Rnd 1:** With larger hook, ch 402, dc in 4th ch from hook (skipped 3 ch count as dc) and in each ch across. Without twisting ch, sl st in first dc to join and form ring—399 dc.

**Rnd 2:** Bpc (see Stitch Guide), \*sk next 4 dc, 9 tr in next dc, sk next 4 dc\*\*, pc in next dc; rep from \* around ending last rep at \*\*, sl st in bpc to join—40 9-tr sh and 40 pc.

**Rnds 3–14:** Bpc, 9 tr in center tr of next sh (see Stitch Guide), \*pc in next pc, 9 tr in center tr of next sh; rep from \* around, sl st in bpc to join.

**Rnds 15–16:** Bpc, 7 tr in center tr of next sh, \*pc in next pc, 7 tr in center tr of next sh; rep from \* around, sl st in bpc to join—40 7-tr sh and 40 pc.

**Rnds 17–20:** Bpc, 5 tr in center tr of next sh, \*pc in next pc, 5 tr in center tr of next sh; rep from \* around, sl st in bpc to join—40 5-tr sh and 40 pc.

**Rnds 21–25:** Changing to smaller hook, bpc, 5 tr in center tr of next sh, \*pc in next pc, 5 tr in center tr of next sh; rep from \* around, sl st in bpc to join. Fasten off.

#### Cowl:

**Rnd 26:** Join yarn with sc in center tr of any 5-tr sh, ch 4, \*sc in center tr of next 5-tr sh, ch 4; rep from \* around, sl st in first sc to join—20 sc and 20 ch-4 sps.

**Rnd 27:** Ch 2, 4 hdc in ch-4 sp, \*hdc in next sc, 4 hdc in ch-4 sp; rep from \* around, sl st in top of beg ch 2 to join—199 hdc.

**Rnd 28:** Bpc, \*sk next 4 hdc, 9 tr in next hdc, sk next 4 hdc\*\*, pc in next hdc; rep from

\* around ending last rep at \*\*, sl st in bpc to join—20 9-tr sh and 20 pc.

**Rnds 29–52:** Bpc, 9 tr in center tr of next sh, \*pc in next pc, 9 tr in center tr of next sh; rep from \* around, sl st in bpc to join. Fasten off.

#### Beaded trim:

With larger hook and working in bottom lps of foundation ch, join first and last dc of first rnd with sl st, sk next 4 ch, 5 tr in next ch, slide bead to hook, ch 1, 4 tr in same ch as 5 tr, \*sk next 4 chs, sl st in next ch, sk next 4 ch, 5 tr in next ch, slide bead to hook, ch 1, 4 tr in same ch as 5 tr; rep from \* around, sl st in first st to join. Fasten off.

### FINISHING

Weave in ends. Block to measurements. ❁

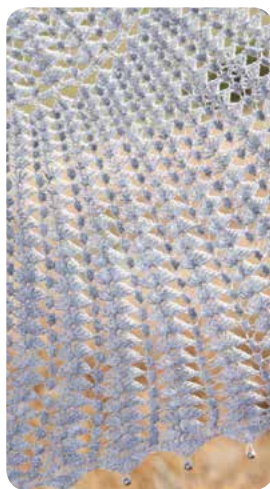
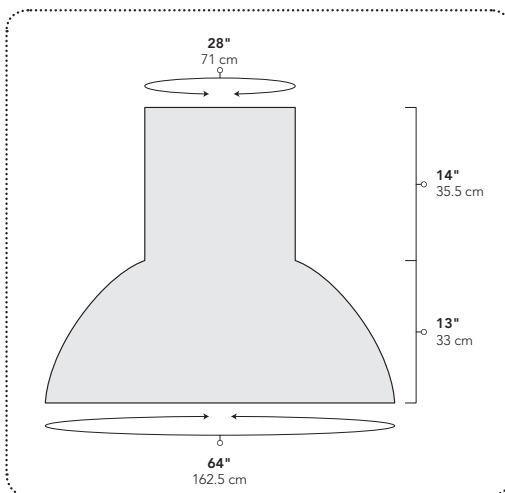



## Royal Mitts & Cowl

Rebekah Thompson



### TUNISIAN

#### Getting Started

**FINISHED SIZE** Cowl: 20 (21¼, 22½)" circumference and 8½" long to fit women's small (medium, large). Garment shown measures 21¼". Mitts: 7½ (8, 8½)" circumference and 7½" long to fit women's small (medium, large). Garment shown measures 8".

**YARN** Spud & Chloë Sweater (55% superwash wool, 45% organic cotton; 160 yd [146 m]/3½ oz [100 g]; **(4)**): #7516 grape jelly (MC); #7515 cider (CC), 1 skein each for cowl; 1 skein each for mitts. Yarn distributed by Blue Sky Alpacos.

**HOOK** Size H/8 (5 mm) double-ended hook. Adjust hook size if necessary to obtain correct gauge.

**NOTIONS** St marker (m); yarn needle.

**GAUGE** 13 sts and 12 rows = 4" in honeycomb patt.

#### Notes

Cowl and mitts beg with foundation row joined in the rnd. Sts are then picked up and worked in a spiral.

Mitts are identical; left and right worked the same.

Incs are worked in pairs to preserve honeycomb patt.

Move m up as work progresses.

Tss is always worked into tps and tps into tss for honeycomb patt.

When hook is half full, turn work to WS, slide lps to other end of hook. With other end of hook and CC, work RetP (see Glossary), leaving at least 3 lps on hook until final bo.

Piece is worked with RS facing while pulling up lps in MC and WS facing while working off loops in CC.

#### Stitch Guide

**Honeycomb patt (worked over an odd number of sts):**

**Rnd 1:** With MC, tss (see Glossary) in first st, \*tps (see Glossary) in next st, tss in next st; rep from \* around, and at the same time work lps off with CC (see Notes).

**Rnd 2:** With MC, tps in first st, \*tss in next st, tps in next st; rep from \* around, and at the same time work lps off with CC. Rep Rnds 1–2 for patt.

**Increase (inc):** (Tps, tss) in indicated st.

**Slip-stitch bind-off (sl st bo):**

Beg by working off all lps on hook except for 1 CC lp, drop CC and pick up MC, with RS facing, \*insert hook in next st in patt (a tss into a tps, etc.), yo and draw through both the st and lp on hook; rep from \* around, join with sl st in first st.

#### Pattern



#### COWL

**Rnd 1:** With MC, fsc 64 (68, 72) (see Glossary), being careful not to twist, sl st in first sc to join, place marker (pm) in lp on hook (counts as first lp of Rnd 2).

**Rnd 2:** (RS) Beg in same st as join, pull up lp blo in each st around, working lps off with CC (see Notes)—65 (69, 73) lps.

**Rnds 3–22:** Work Rnds 1–2 of honeycomb patt (see Stitch Guide).

**Rnd 23:** Sl st bo (see Stitch Guide). Fasten off CC, do not fasten off MC.

**Rnd 24:** Ch 1, sc in same st as join, \*ch 1, sk next st, sc in next st; rep from \* around, sl st in beg ch-1 to join. Fasten off MC.



#### MITTS (MAKE 2)

**Rnd 1:** With MC, fsc 20 (22, 24) (see Glossary), being careful not to twist, sl st in first

sc to join, place marker (pm) in lp on hook (counts as first lp of Rnd 2).

**Rnd 2:** (RS) Beg in same st as join, pull up lp blo in each st around, at the same time work lps off with CC (see Notes)—21 (23, 25) lps.

**Rnd 3:** Work Rnd 1 of honeycomb patt.

**Rnd 4:** Work Rnd 2 of honeycomb patt.

**Rnds 5–9:** Work even in patt.

**Rnd 10:** Inc (see Stitch Guide) in marked (first) st and next st, move m to 2nd st of first inc (this is now first st of rnd), cont in patt to end of rnd—23 (25, 27) sts.

**Rnds 11–12:** Work even in patt.

**Rnds 13:** Rep Rnd 10—25 (27, 29) sts.

**Rnds 14–16:** Rep Rnds 11–13—27 (29, 31) sts.

**Rnd 17:** Work Rnd 2 of honeycomb patt, pausing after first 3 lps are pulled up, pm in 2nd st to right and 3rd st to left of marked st at beg of rnd (thumb), cont in patt to end of rnd, working inc in st before first thumb m, and work off all lps but one MC and CC. Leaving CC lp on hook, with MC sl st bo (see Stitch Guide) 6 sts bet thumb m, pm in last MC lp for first st of next rnd and remove all other m—22 (24, 26) sts.

**Rnd 18:** Inc in first st after bo, cont working in patt, holding thumb closed while sts over thumb opening are worked off—23 (25, 27) sts.

**Rnds 19–20:** Work even in patt.

**Rnd 21:** Work sl st bo. Fasten off.



#### FINISHING

Weave in ends.

#### Tie for Cowl:

Make a ch 35 (36, 37)" long. Weave in ends. Beg in ch-sp to the left of first sc on Rnd 24, weave tie in and out of ch-sps around.

#### Trim:

With WS facing, turn work so that ch edge of fsc is on top and join CC with sl st in blo in any st. Working in blo, hdc in next st, \*sl st in next st, hdc in next st; rep from \* around, sl st in first sl st to join. Fasten off. Weave in ends. ❁

REBEKAH THOMPSON lives in rural Michigan, where she homeschools the youngest of four children. She enjoys singing, taking piano lessons from her daughter-in-law, and teaching crochet.



### Finished Size

4½" wide × 62" long before joining (11.5 × 157.5 cm).

### Yarn

Sportweight (#2 Fine).

*Shown here:* Zitron Unisono #1170 (100% virgin wool; 328 yd [300 m]/3½ oz [100 g]); #1170 solid off-white (MC), #1210 red, green, aqua multicolored (CC), 1 skein each. Yarn distributed by Skacel.

### Hook

Size F/5 (3.75 mm). *Adjust hook size if necessary to obtain correct gauge.*

### Notions

Yarn needle.

### Gauge

One chevron = 2¼" (5.5 cm) wide; 6 rows = 2" (5 cm), after blocking.

### Note

*Gauge is crucial to the success of this project. The self-striping yarn lines up perfectly in the stitch pattern and gauge after blocking. Take care to block your swatch. It may be necessary to rip back and crochet more or less loosely.*



## Rocksteady COWL

This cowl may look like it has a million ends to weave in, but the yarn does all the work! This self-striping sock yarn matches up perfectly with a neutral color, and the chevrons in the stitch pattern make a bold and graphic, yet cozy, statement. Wear it doubled for extra warmth during chilly winter days.

**DESIGNED BY** *Sharon Zientara*

## Stitch Guide

**Color Change:** Work st indicated to last yo, complete last yo with new color. Before making next st, move old color of yarn between hook and new yarn and complete next st. Lightly tug on the old yarn to ensure a clean color change.



## Cowl

With MC, ch 29.

**ROW 1:** Working in bottom ridge lps of foundation ch, dc in 4th ch from hook (beg ch-3 counts as dc), [sk next ch, dc in next ch] twice, dc in next ch, 5 dc in next ch, dc in each of next 2 ch, [sk next ch, dc in next ch] twice, change to CC (see Stitch Guide) in last yo of last dc, with CC, [sk next ch, dc in next ch] twice, dc in next ch, 5 dc in next ch, dc in each of next 2 ch, [sk next ch, dc in next ch] twice, dc in last ch, turn.

**ROW 2:** With CC, ch 1 (does not count as st), sc in first 13 dc, change to MC, sc in each st across, turn.

**ROW 3:** Ch 3 (counts as dc here and throughout), dc in next sc, \*[sk next sc, dc in next sc] twice, dc in next sc, 5 dc in next sc, dc in each of next 2 sc, [sk next sc, dc in next sc] twice, change to CC, with CC, [sk next sc, dc in next sc] twice, dc in next sc, 5 dc in next sc, dc in next 2 sc, [sk next sc, dc in next sc] twice, dc in last sc, turn.

**ROWS 4–5:** Rep Rows 2–3 once.

**ROW 6:** Ch 1, sc in each st across without changing color, turn.

**ROW 7:** Working with CC, change to MC, rep Row 3.

**ROWS 8–11:** Maintaining established color sequence, rep Rows 2–3 (twice).

**ROW 12:** With MC, rep Row 6.

**ROW 13:** Rep Row 3.

**ROWS 14–180:** Rep Rows 2–13 (13 times); rep Rows 2–12 once.

## Finishing

Weave in ends. Wet block to measurements. Sl st seam (see Glossary) ends of cowl together.

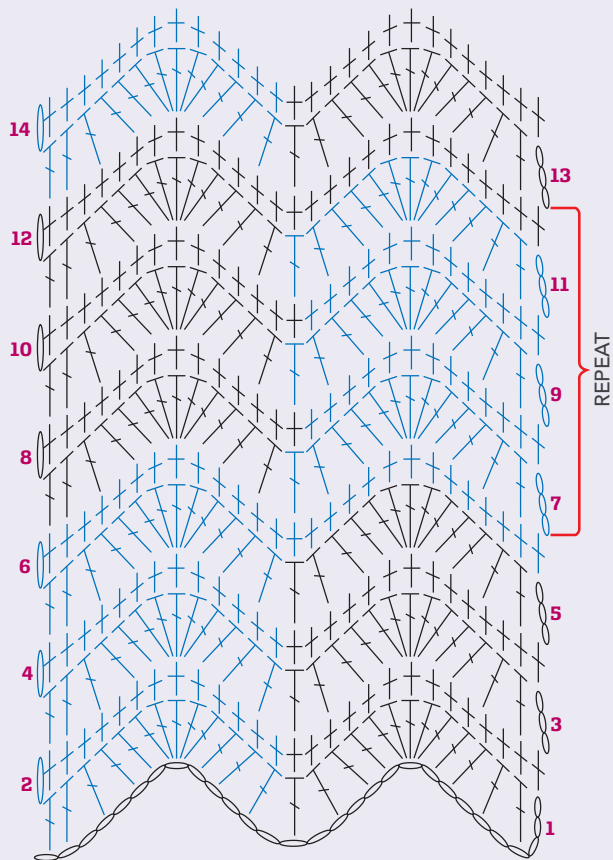

### Stitch Key

○ = chain (ch)

⊕ = single crochet (sc)

⌋ = double crochet (dc)

### Inspiration

In the 1960s, Jamaican street culture informed the style of mod-era fashion, especially in the United Kingdom. With Jamaican culture came all forms of music, including rocksteady, which was popular after ska and before reggae. The graphic rainbow shades in this scarf paired with the clean lines of a chevron stitch remind me of the colorful nature of Jamaican culture with a touch of British sophistication.

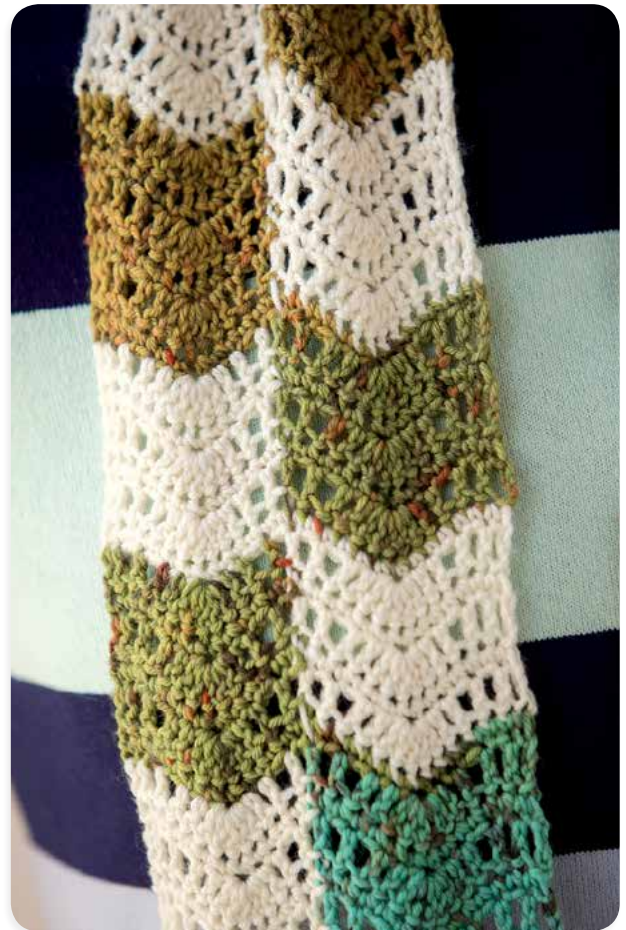

fossil  
NECKWARMER



PHOTOS BY JOE HANCOCK

The pattern this yarn creates when simply stitched in circles reminds designer Kathy Merrick of the traces of ancient creatures left behind in rocks. The yarn's softness feels wonderful against the sensitive skin of the neck. A quick and handy gift with style.

**FINISHED SIZE** 24¼" (61.5 cm) circumference and 9½" (24 cm) from top to bottom, measured after blocking.

**YARN** Bulky weight (Bulky #5), 196 yd (179 m).

*Shown here:* DiVé Autunno (100% extrafine Merino wool; 98 yd [90 m]/50 g); pink mix #14627, 2 balls.

**HOOK** Size K/10.5 (6.5mm). Adjust hook size if necessary to obtain the correct gauge.

**NOTIONS** Removable stitch marker (m); tapestry needle.

**GAUGE** Large motif = 4¾" (12 cm) diameter, measured after blocking.

**NOTES**

- + Work motifs in spiral fashion; do not join rounds with slip stitch.
- + Place marker (pm) at beginning of round, then move the marker up as work progresses.

### First Motif

**Rnd 1:** Ch 3 (counts as hdc here and throughout), 7 hdc in 3rd ch from hook, do not join, place marker (pm) in first st to mark beg of rnd (see Notes)—8 hdc.

**Rnd 2:** 2 hdc in each hdc around—16 hdc.

**Rnd 3:** Hdc in each hdc around.

**Rnd 4:** Rep Rnd 2—32 hdc.

**Rnds 5–6:** Rep Rnd 3. Fasten off.

### Remaining Motifs

Work as for first motif except on Rnd 6, join motif to previous motif as foll: [hdc, sl st in corresponding st on previous motif] 4 times, complete rnd as established. Fasten off.

### FIRST RND OF NECKWARMER

Make and join 5 motifs, joining last motif to first motif to form a ring.

### SECOND RND OF NECKWARMER

Make and join 5 motifs as foll: join one side to previous motif over 4 sts, sk next 4 sts, join working motif to corresponding motif on previous rnd over next 4 sts, making sure to skip 4 sts from existing join on corresponding motif as well.

Into skipped space between motifs, work small motif as foll:

**Rnd 1:** Ch 3 (counts as hdc), 7 hdc in 3rd ch from hook—8 hdc.

**Rnd 2:** [Hdc in next st, sl st in first skipped st of large motif, hdc in same st of working motif, sl st in next skipped st of large motif] 2 times to join each side of small motif to each of the 4 adjoining larger motifs—16 sts. Fasten off.

### EDGING

Join yarn to center st of one of top-rnd motifs, \*sc in next 3 sts, 2 sc in next st; rep from \* around top edge, working sc in each join. Fasten off. Rep for lower edge of neckwarmer.

### FINISHING

Weave in loose ends. Steam gently to shape.



## Abbreviations

beg	begin(s); beginning
bet	between
blo	back loop only
CC	contrasting color
ch	chain
cm	centimeter(s)
cont	continue(s); continuing
dc	double crochet
dtr	double treble crochet
dec(s)('d)	decrease(s); decreasing; decreased
est	established
fdc	foundation double crochet
flo	front loop only
fol	follows; following
fsc	foundation single crochet
g	gram(s)
hdc	half double crochet
inc(s)('d)	increase(s); increasing; increased
k	knit
lp(s)	loop(s)
MC	main color
m	marker
mm	millimeter(s)
patt(s)	pattern(s)
pm	place marker
p	purl
rem	remain(s); remaining
rep	repeat; repeating
rev sc	reverse single crochet
rnd(s)	round(s)
RS	right side
sc	single crochet
sk	skip
sl	slip
sl st	slip(ped) stitch
sp(s)	space(es)
st(s)	stitch(es)
tch	turning chain
tog	together
tr	treble crochet
WS	wrong side
yd	yard
yo	yarn over hook
*	repeat starting point
()	alternate measurements and/or instructions
[]	work bracketed instructions a specified number of times

## Concentration Ratings:

- 1 2 3 4** **LITTLE CONCENTRATION REQUIRED.**  
Straightforward stitching means your hands can work on autopilot.
- 1 2 3 4** **SOME CONCENTRATION REQUIRED.**  
Easily memorized stitch patterns and minimal shaping might require some focus and counting.
- 1 2 3 4** **FAIR AMOUNT OF FOCUS REQUIRED.**  
Involved stitch patterns, shaping, or assembly require fairly constant concentration.
- 1 2 3 4** **EXTREME FOCUS REQUIRED.**  
Unusual techniques or complex stitch patterns and shaping require constant focus.

## FOUNDATION SINGLE CROCHET (FSC)

Start with a slipknot, chain 2. Insert hook in second chain from hook, pull up a loop. Yarn over, draw through 1 loop (the “chain”). Yarn over, draw through 2 loops (the single crochet). One sc with its own ch st (shaded) at the bottom. \*Insert hook under the 2 loops of the “ch” st (shaded) of the last st and pull up a loop, yarn over and draw through 1 loop, yarn over and draw through 2 loops. Repeat from \* for length of foundation.

## TUNISIAN BIND-OFF (BO)

\*Insert hook behind front vertical bar, yarn over and pull up loop, yarn over and draw through both loops on hook; repeat from \* across.

## TUNISIAN MAKE 1 INC (M1)

Insert hook in space between next 2 vertical bars (unless otherwise noted), pull up loop.

## TUNISIAN KNIT STITCH (TKS)

*Tks forward pass (Fwp)*: Skip first vertical bars, with yarn in back, \*insert hook between next vertical bars under horizontal strands (Figure 1), yarn over and pull up loop, leave loop on hook; repeat from \* to end, ending with 1 loop on hook; return pass.

*Return pass (RetP)*: Yarn over and draw loop through first loop on hook, \*yarn over and draw through 2 loops on hook: repeat from \* across (Figure 2), ending with 1 loop on hook.

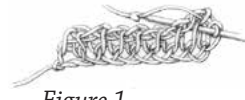

Figure 1

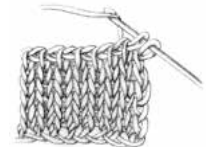

Figure 2

## TUNISIAN PURL STITCH (TPS)

*Tps forward pass (FwP)*: \*Insert hook from right to left behind front vertical bar, yarn over and pull up loop (see Figure), leave loop on hook; repeat from \* to last vertical bar at edge, pick up front and back loops of last bar to create firm edge; return pass.



*Return pass (RetP)*: Yarn over and draw loop through first loop on hook, \*yarn over and draw through 2 loops on hook: repeat from \* to end, ending with 1 loop on hook.

## TUNISIAN SIMPLE STITCH (TSS)

*Tss forward pass (FwP)*: \*Insert hook from right to left behind front vertical bar (Figure 1), yarn over and pull up loop (Figure 2), leave loop on hook; repeat from \* to last vertical bar at edge, pick up front and back loops of last bar to create firm edge; return pass.

*Return pass (RetP)*: Yarn over and draw through first loop on hook, \*yarn over and draw through 2 loops on hook (Figure 3); repeat from \* to end, ending with 1 loop on hook.



Figure 1



Figure 2

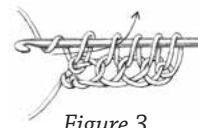

Figure 3